

# Transverse structure of the nucleon

## Part 2: Theory background

---

Alessandro Bacchetta



# DIS and structure functions

---

# Deep inelastic scattering

---

$$\ell(l) + N(P) \rightarrow \ell(l') + h(P_h) + X,$$

$$x_B = \frac{Q^2}{2P \cdot q},$$

$$y = \frac{P \cdot q}{P \cdot l},$$

$$z_h = \frac{P \cdot P_h}{P \cdot q}.$$

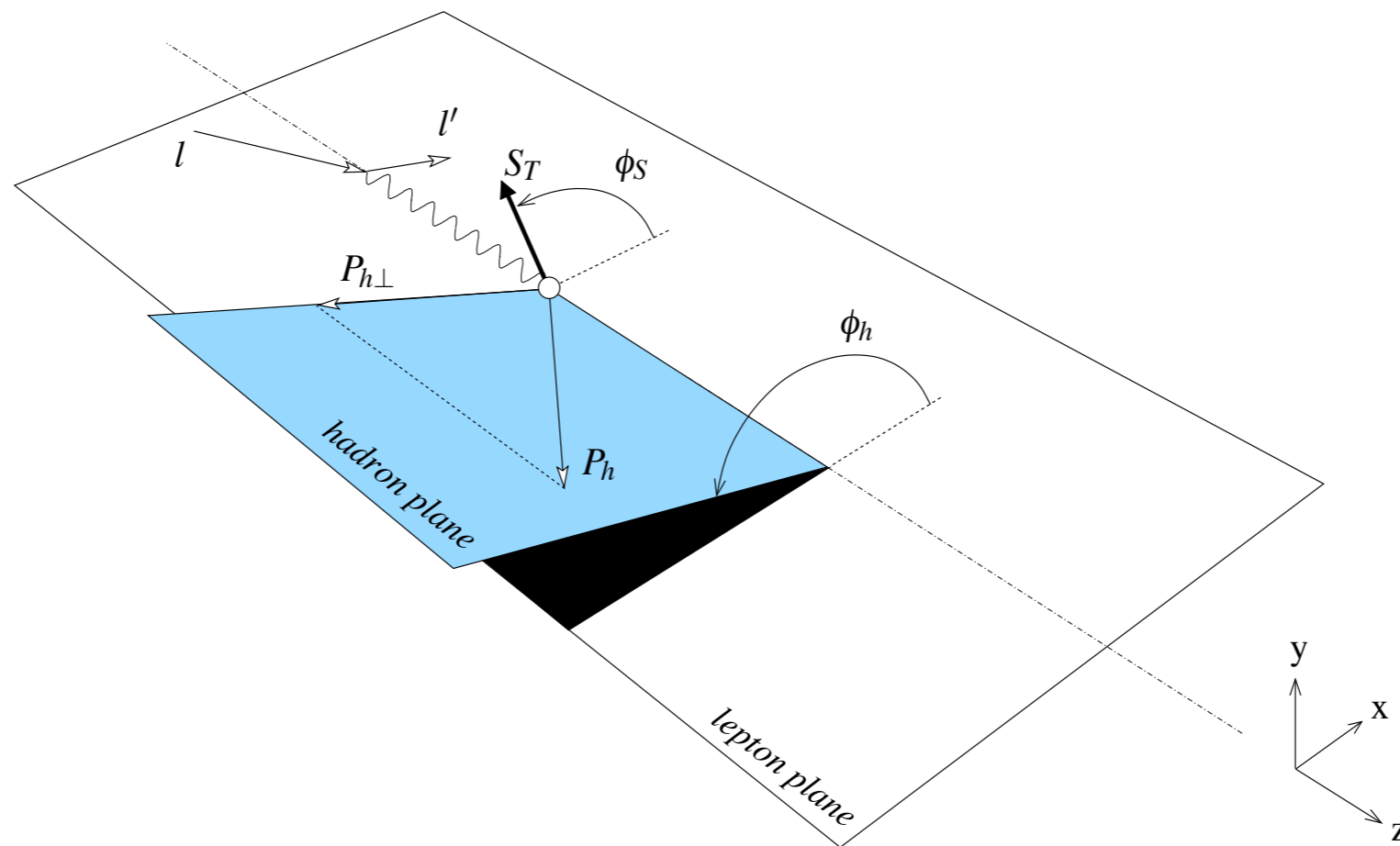

# Inclusive DIS

---

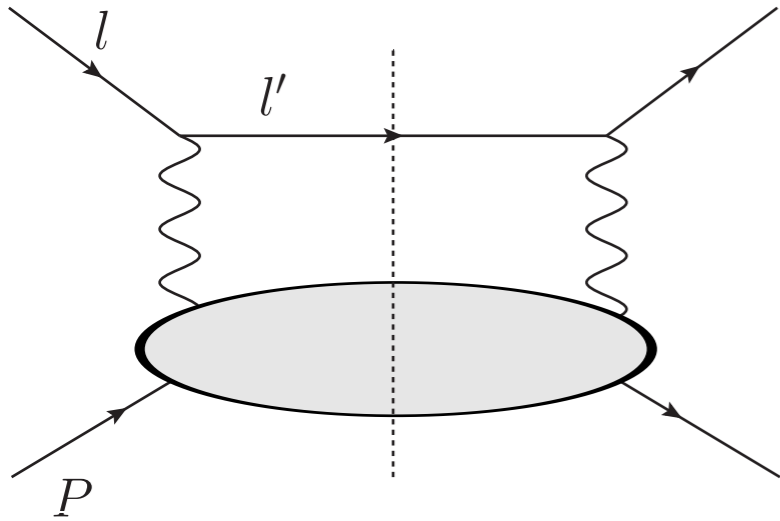

$$\frac{d^3\sigma}{dx_B dy d\phi_S} = \frac{\alpha^2 y}{2Q^4} L_{\mu\nu}(l, l', \lambda_e) 2MW^{\mu\nu}(q, P, S)$$

# Inclusive DIS

---

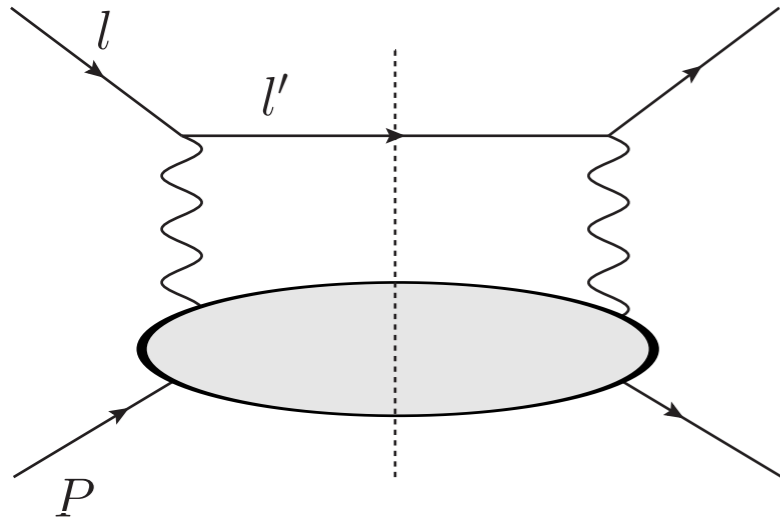

$$\frac{d^3\sigma}{dx_B dy d\phi_S} = \frac{\alpha^2 y}{2Q^4} L_{\mu\nu}(l, l', \lambda_e) 2MW^{\mu\nu}(q, P, S)$$

*Single-photon-exchange approximation*

# Inclusive DIS

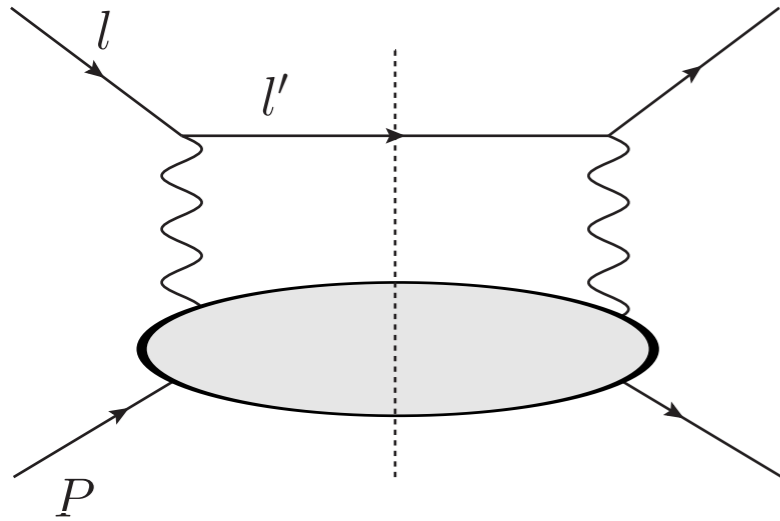

$$\frac{d^3\sigma}{dx_B dy d\phi_S} = \frac{\alpha^2 y}{2Q^4} L_{\mu\nu}(l, l', \lambda_e) 2MW^{\mu\nu}(q, P, S)$$

*Single-photon-exchange approximation*

$$L_{\mu\nu} = \sum_{\lambda'_e} \left( \bar{u}(l', \lambda'_e) \gamma_\mu u(l, \lambda_e) \right)^* \left( \bar{u}(l', \lambda'_e) \gamma_\nu u(l, \lambda_e) \right)$$

$$= -Q^2 g_{\mu\nu} + 2(l_\mu l'_\nu + l'_\mu l_\nu) + 2i \lambda_e \epsilon_{\mu\nu\rho\sigma} l^\rho l'^\sigma$$

$$= \frac{2Q^2}{y^2} \left[ -\left(1 - y + \frac{y^2}{2}\right) g_{\perp\mu\nu} + 2(1 - y) \hat{t}_\mu \hat{t}_\nu \right.$$

$$\left. + 2(1 - y) \left( \hat{l}_\mu \hat{l}_\nu + \frac{1}{2} g_{\perp\mu\nu} \right) \right.$$

$$\left. - i\lambda_e y \left(1 - \frac{y}{2}\right) \epsilon_{\perp\mu\nu} - i\lambda_e y \sqrt{1 - y} \hat{t}_{[\mu} \epsilon_{\perp\nu]\rho} \hat{l}^\rho + \dots \right]$$

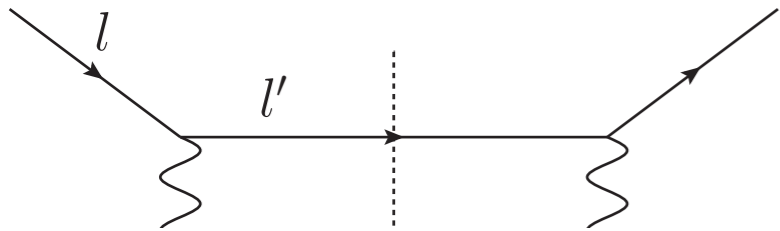

# Lepton tensor

---

$$l^\mu = \left( \frac{(2-y)Q}{2y}, \frac{\sqrt{1-y}Q}{y}, 0, \frac{Q}{2} \right),$$
$$l'^\mu = \left( \frac{(2-y)Q}{2y}, \frac{\sqrt{1-y}Q}{y}, 0, -\frac{Q}{2} \right)$$

# Lepton tensor

---

$$l^\mu = \left( \frac{(2-y)Q}{2y}, \frac{\sqrt{1-y}Q}{y}, 0, \frac{Q}{2} \right),$$
$$l'^\mu = \left( \frac{(2-y)Q}{2y}, \frac{\sqrt{1-y}Q}{y}, 0, -\frac{Q}{2} \right)$$

$$L_{\mu\nu}(\lambda_e = 0) = \frac{2Q^2}{y^2} \begin{pmatrix} 2(1-y) & \dots & 0 & 0 \\ \dots & \left(1-y + \frac{y^2}{2}\right) + (1-y) & 0 & 0 \\ 0 & 0 & \left(1-y + \frac{y^2}{2}\right) - (1-y) & 0 \\ 0 & 0 & 0 & 0 \end{pmatrix}$$



# Lepton tensor

---

$$l^\mu = \left( \frac{(2-y)Q}{2y}, \frac{\sqrt{1-y}Q}{y}, 0, \frac{Q}{2} \right),$$

$$l'^\mu = \left( \frac{(2-y)Q}{2y}, \frac{\sqrt{1-y}Q}{y}, 0, -\frac{Q}{2} \right)$$

$$L_{\mu\nu}(\lambda_e = 0) = \frac{2Q^2}{y^2} \begin{pmatrix} 2(1-y) & \dots & 0 & 0 \\ \dots & \left(1-y + \frac{y^2}{2}\right) + (1-y) & 0 & 0 \\ 0 & 0 & \left(1-y + \frac{y^2}{2}\right) - (1-y) & 0 \\ 0 & 0 & 0 & 0 \end{pmatrix}$$

$$\epsilon_x^\mu = \begin{pmatrix} 0 \\ 1 \\ 0 \\ 0 \end{pmatrix},$$

$$\epsilon_y^\mu = \begin{pmatrix} 0 \\ 0 \\ 1 \\ 0 \end{pmatrix},$$

$$\epsilon_L^\mu = \begin{pmatrix} 1 \\ 0 \\ 0 \\ 0 \end{pmatrix}$$

# Helicity vs transversity / circular vs linear

---

$$\chi_+ = \begin{pmatrix} 1 \\ 0 \end{pmatrix}$$

$$\chi_- = \begin{pmatrix} 0 \\ 1 \end{pmatrix}$$

$$\chi_{\uparrow} = \frac{1}{\sqrt{2}}(\chi_+ + e^{i\phi_s}\chi_-) = \frac{1}{\sqrt{2}} \begin{pmatrix} 1 \\ e^{i\phi_s} \end{pmatrix}$$

$$\chi_{\downarrow} = \frac{1}{\sqrt{2}}(\chi_+ - e^{i(\phi_s+\pi)}\chi_-) = \frac{1}{\sqrt{2}} \begin{pmatrix} 1 \\ e^{i(\phi_s+\pi)} \end{pmatrix}$$

# Helicity vs transversity / circular vs linear

---

$$\chi_+ = \begin{pmatrix} 1 \\ 0 \end{pmatrix}$$

$$\chi_- = \begin{pmatrix} 0 \\ 1 \end{pmatrix}$$

$$\chi_{\uparrow} = \frac{1}{\sqrt{2}}(\chi_+ + e^{i\phi_s}\chi_-) = \frac{1}{\sqrt{2}} \begin{pmatrix} 1 \\ e^{i\phi_s} \end{pmatrix}$$

$$\chi_{\downarrow} = \frac{1}{\sqrt{2}}(\chi_+ - e^{i(\phi_s+\pi)}\chi_-) = \frac{1}{\sqrt{2}} \begin{pmatrix} 1 \\ e^{i(\phi_s+\pi)} \end{pmatrix}$$

$$\epsilon_+^{\mu} = \frac{1}{\sqrt{2}} \begin{pmatrix} 0 \\ 1 \\ i \\ 0 \end{pmatrix},$$

$$\epsilon_-^{\mu} = \frac{1}{\sqrt{2}} \begin{pmatrix} 0 \\ 1 \\ -i \\ 0 \end{pmatrix},$$

$$\epsilon_x^{\mu} = \frac{1}{\sqrt{2}}(\epsilon_+^{\mu} + \epsilon_-^{\mu}) = \begin{pmatrix} 0 \\ 1 \\ 0 \\ 0 \end{pmatrix},$$

$$\epsilon_y^{\mu} = \frac{i}{\sqrt{2}}(\epsilon_+^{\mu} - \epsilon_-^{\mu}) = \begin{pmatrix} 0 \\ 0 \\ 1 \\ 0 \end{pmatrix}$$

# Helicity conservation

---

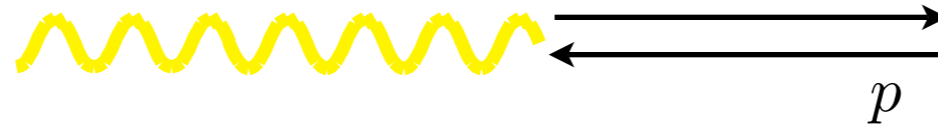

$$\bar{u}_+(-p_z)\gamma^\mu u_+(p_z) \sim (0, 1, i, 0)$$

$$\bar{u}^\uparrow(-p_z)\gamma^\mu u^\uparrow(p_z) \sim (0, \cos \phi_s, -\sin \phi_s, 0)$$

$$\bar{u}_-(-p_z)\gamma^\mu u_+(p_z) = 0$$

$$\bar{u}^\downarrow(-p_z)\gamma^\mu u^\uparrow(p_z) = 0$$

# Structure functions

---

$$\frac{d^3\sigma}{dx_B dy d\phi_S} = \frac{\alpha^2 y}{2Q^4} L_{\mu\nu}(l, l', \lambda_e) 2MW^{\mu\nu}(q, P, S)$$

# Structure functions

---

$$\frac{d^3\sigma}{dx_B dy d\phi_S} = \frac{\alpha^2 y}{2Q^4} L_{\mu\nu}(l, l', \lambda_e) 2MW^{\mu\nu}(q, P, S)$$

$$2MW^{\mu\nu} = \frac{1}{x} \left[ -g_{\perp}^{\mu\nu} F_{UU,T} + \hat{t}^{\mu} \hat{t}^{\nu} F_{UU,L} + iS_L \epsilon_{\perp}^{\mu\nu} F_{LL} - i\hat{t}^{[\mu} \epsilon_{\perp}^{\nu]\rho} S_{\rho} F_{LT}^{\cos \phi_S} \right]$$

# Structure functions

---

$$\frac{d^3\sigma}{dx_B dy d\phi_S} = \frac{\alpha^2 y}{2Q^4} L_{\mu\nu}(l, l', \lambda_e) 2MW^{\mu\nu}(q, P, S)$$

$$2MW^{\mu\nu} = \frac{1}{x} \left[ -g_{\perp}^{\mu\nu} F_{UU,T} + \hat{t}^{\mu} \hat{t}^{\nu} F_{UU,L} + iS_L \epsilon_{\perp}^{\mu\nu} F_{LL} - i\hat{t}^{[\mu} \epsilon_{\perp}^{\nu]\rho} S_{\rho} F_{LT}^{\cos \phi_S} \right]$$

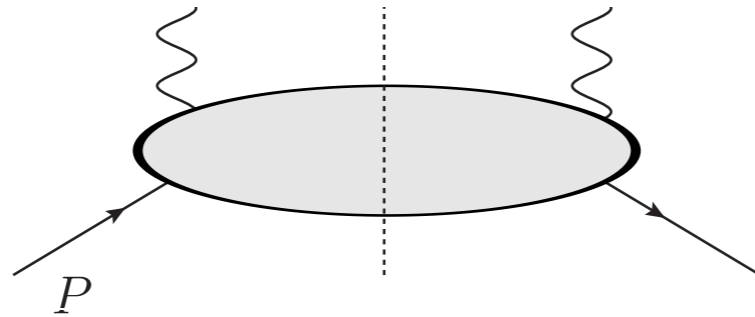

# Structure functions

---

$$\frac{d^3\sigma}{dx_B dy d\phi_S} = \frac{\alpha^2 y}{2Q^4} L_{\mu\nu}(l, l', \lambda_e) 2MW^{\mu\nu}(q, P, S)$$

$$2MW^{\mu\nu} = \frac{1}{x} \left[ -g_{\perp}^{\mu\nu} F_{UU,T} + \hat{t}^{\mu} \hat{t}^{\nu} F_{UU,L} + iS_L \epsilon_{\perp}^{\mu\nu} F_{LL} - i\hat{t}^{[\mu} \epsilon_{\perp}^{\nu]\rho} S_{\rho} F_{LT}^{\cos \phi_S} \right]$$

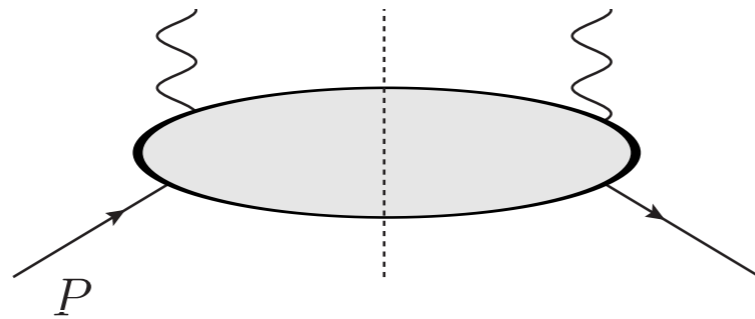

$$\frac{d\sigma}{dx_B dy d\phi_S} = \frac{2\alpha^2}{x_B y Q^2} \left\{ \left(1 - y + \frac{y^2}{2}\right) F_{UU,T} + (1 - y) F_{UU,L} + S_L \lambda_e y \left(1 - \frac{y}{2}\right) F_{LL} + |\mathbf{S}_T| \lambda_e y \sqrt{1 - y} \cos \phi_S F_{LT}^{\cos \phi_S} \right\}$$



# Semi-inclusive DIS

---

$$\frac{d^3\sigma}{dx_B dy d\phi_S} = \frac{\alpha^2 y}{2Q^4} L_{\mu\nu}(l, l', \lambda_e) 2MW^{\mu\nu}(q, P, S)$$

# Semi-inclusive DIS

---

$$\frac{d^3\sigma}{dx_B dy d\phi_S} = \frac{\alpha^2 y}{2Q^4} L_{\mu\nu}(l, l', \lambda_e) 2MW^{\mu\nu}(q, P, S)$$

$$\frac{2E_h d^6\sigma}{d^3P_h dx_B dy d\phi_S} = \frac{\alpha^2 y}{2Q^4} L_{\mu\nu}(l, l', \lambda_e) 2MW^{\mu\nu}(q, P, S, P_h)$$

# Semi-inclusive DIS

---

$$\frac{d^3\sigma}{dx_B dy d\phi_S} = \frac{\alpha^2 y}{2Q^4} L_{\mu\nu}(l, l', \lambda_e) 2MW^{\mu\nu}(q, P, S)$$

$$\frac{2E_h d^6\sigma}{d^3P_h dx_B dy d\phi_S} = \frac{\alpha^2 y}{2Q^4} L_{\mu\nu}(l, l', \lambda_e) 2MW^{\mu\nu}(q, P, S, P_h)$$

$$\frac{d^6\sigma}{dx_B dy dz_h d\phi_S d\phi_h dP_{h\perp}^2} = \frac{\alpha^2 y}{2z_h Q^4} L_{\mu\nu}(l, l', \lambda_e) 2MW^{\mu\nu}(q, P, S, P_h)$$

# Structure functions

---

$$\begin{aligned}
 & \frac{d\sigma}{dx dy d\phi_S dz d\phi_h dP_{h\perp}^2} \\
 &= \frac{\alpha^2}{xy Q^2} \frac{y^2}{2(1-\varepsilon)} \left\{ F_{UU,T} + \varepsilon F_{UU,L} + \sqrt{2\varepsilon(1+\varepsilon)} \cos\phi_h F_{UU}^{\cos\phi_h} + \varepsilon \cos(2\phi_h) F_{UU}^{\cos 2\phi_h} \right. \\
 &+ \lambda_e \sqrt{2\varepsilon(1-\varepsilon)} \sin\phi_h F_{LU}^{\sin\phi_h} + S_L \left[ \sqrt{2\varepsilon(1+\varepsilon)} \sin\phi_h F_{UL}^{\sin\phi_h} + \varepsilon \sin(2\phi_h) F_{UL}^{\sin 2\phi_h} \right] \\
 &+ S_L \lambda_e \left[ \sqrt{1-\varepsilon^2} F_{LL} + \sqrt{2\varepsilon(1-\varepsilon)} \cos\phi_h F_{LL}^{\cos\phi_h} \right] \\
 &+ S_T \left[ \sin(\phi_h - \phi_S) \left( F_{UT,T}^{\sin(\phi_h - \phi_S)} + \varepsilon F_{UT,L}^{\sin(\phi_h - \phi_S)} \right) + \varepsilon \sin(\phi_h + \phi_S) F_{UT}^{\sin(\phi_h + \phi_S)} \right. \\
 &+ \varepsilon \sin(3\phi_h - \phi_S) F_{UT}^{\sin(3\phi_h - \phi_S)} + \sqrt{2\varepsilon(1+\varepsilon)} \sin\phi_S F_{UT}^{\sin\phi_S} \\
 &+ \left. \left. \sqrt{2\varepsilon(1+\varepsilon)} \sin(2\phi_h - \phi_S) F_{UT}^{\sin(2\phi_h - \phi_S)} \right] + S_T \lambda_e \left[ \sqrt{1-\varepsilon^2} \cos(\phi_h - \phi_S) F_{LT}^{\cos(\phi_h - \phi_S)} \right. \right. \\
 &+ \left. \left. \sqrt{2\varepsilon(1-\varepsilon)} \cos\phi_S F_{LT}^{\cos\phi_S} + \sqrt{2\varepsilon(1-\varepsilon)} \cos(2\phi_h - \phi_S) F_{LT}^{\cos(2\phi_h - \phi_S)} \right] \right\}
 \end{aligned}$$

see e.g. AB, Diehl, Goeke, Metz, Mulders, Schlegel, JHEP093 (07)

# Structure functions

$$\begin{aligned}
 & \frac{d\sigma}{dx dy d\phi_S dz d\phi_h dP_{h\perp}^2} F_{UU,T}(x, z, P_{h\perp}^2, Q^2) \\
 &= \frac{\alpha^2}{xy Q^2} \frac{y^2}{2(1-\varepsilon)} \left\{ F_{UU,T} + \varepsilon F_{UU,L} + \sqrt{2\varepsilon(1+\varepsilon)} \cos\phi_h F_{UU}^{\cos\phi_h} + \varepsilon \cos(2\phi_h) F_{UU}^{\cos 2\phi_h} \right. \\
 &+ \lambda_e \sqrt{2\varepsilon(1-\varepsilon)} \sin\phi_h F_{LU}^{\sin\phi_h} + S_L \left[ \sqrt{2\varepsilon(1+\varepsilon)} \sin\phi_h F_{UL}^{\sin\phi_h} + \varepsilon \sin(2\phi_h) F_{UL}^{\sin 2\phi_h} \right] \\
 &+ S_L \lambda_e \left[ \sqrt{1-\varepsilon^2} F_{LL} + \sqrt{2\varepsilon(1-\varepsilon)} \cos\phi_h F_{LL}^{\cos\phi_h} \right] \\
 &+ S_T \left[ \sin(\phi_h - \phi_S) \left( F_{UT,T}^{\sin(\phi_h - \phi_S)} + \varepsilon F_{UT,L}^{\sin(\phi_h - \phi_S)} \right) + \varepsilon \sin(\phi_h + \phi_S) F_{UT}^{\sin(\phi_h + \phi_S)} \right. \\
 &+ \varepsilon \sin(3\phi_h - \phi_S) F_{UT}^{\sin(3\phi_h - \phi_S)} + \sqrt{2\varepsilon(1+\varepsilon)} \sin\phi_S F_{UT}^{\sin\phi_S} \\
 &+ \left. \left. \sqrt{2\varepsilon(1+\varepsilon)} \sin(2\phi_h - \phi_S) F_{UT}^{\sin(2\phi_h - \phi_S)} \right] + S_T \lambda_e \left[ \sqrt{1-\varepsilon^2} \cos(\phi_h - \phi_S) F_{LT}^{\cos(\phi_h - \phi_S)} \right. \right. \\
 &+ \left. \left. \sqrt{2\varepsilon(1-\varepsilon)} \cos\phi_S F_{LT}^{\cos\phi_S} + \sqrt{2\varepsilon(1-\varepsilon)} \cos(2\phi_h - \phi_S) F_{LT}^{\cos(2\phi_h - \phi_S)} \right] \right\}
 \end{aligned}$$

see e.g. AB, Diehl, Goeke, Metz, Mulders, Schlegel, JHEP093 (07)

# Light-cone coordinates

---

Light-cone vectors will be indicated as

$$a^\mu = [a^-, a^+, \mathbf{a}_T] = \left[ \frac{a^0 - a^3}{\sqrt{2}}, \frac{a^0 + a^3}{\sqrt{2}}, a^1, a^2 \right]. \quad (1)$$

The dot-product in light-cone components is

$$a \cdot b = a^+ b^- + a^- b^+ - \mathbf{a}_T \cdot \mathbf{b}_T \quad (2)$$

The light-cone decomposition of a vector can be written in a Lorentz covariant fashion using two light-like vectors  $n_+$  and  $n_-$  satisfying  $n_\pm^2 = 0$  and  $n_+ \cdot n_- = 1$  and promoting  $\mathbf{a}_T$  to a four-vector  $a_T^\mu = [0, 0, \mathbf{a}_T]$  so that

$$a^\mu = a^+ n_+^\mu + a^- n_-^\mu + a_T^\mu, \quad (3)$$

where

$$a^+ = a \cdot n_-, \quad a^- = a \cdot n_+, \quad a_T \cdot n_+ = a_T \cdot n_- = 0. \quad (4)$$

Note that

$$a_T \cdot b_T = -\mathbf{a}_T \cdot \mathbf{b}_T \quad (5)$$

# Light-cone coordinates

---

$Q^2$  much higher than any other scalar product

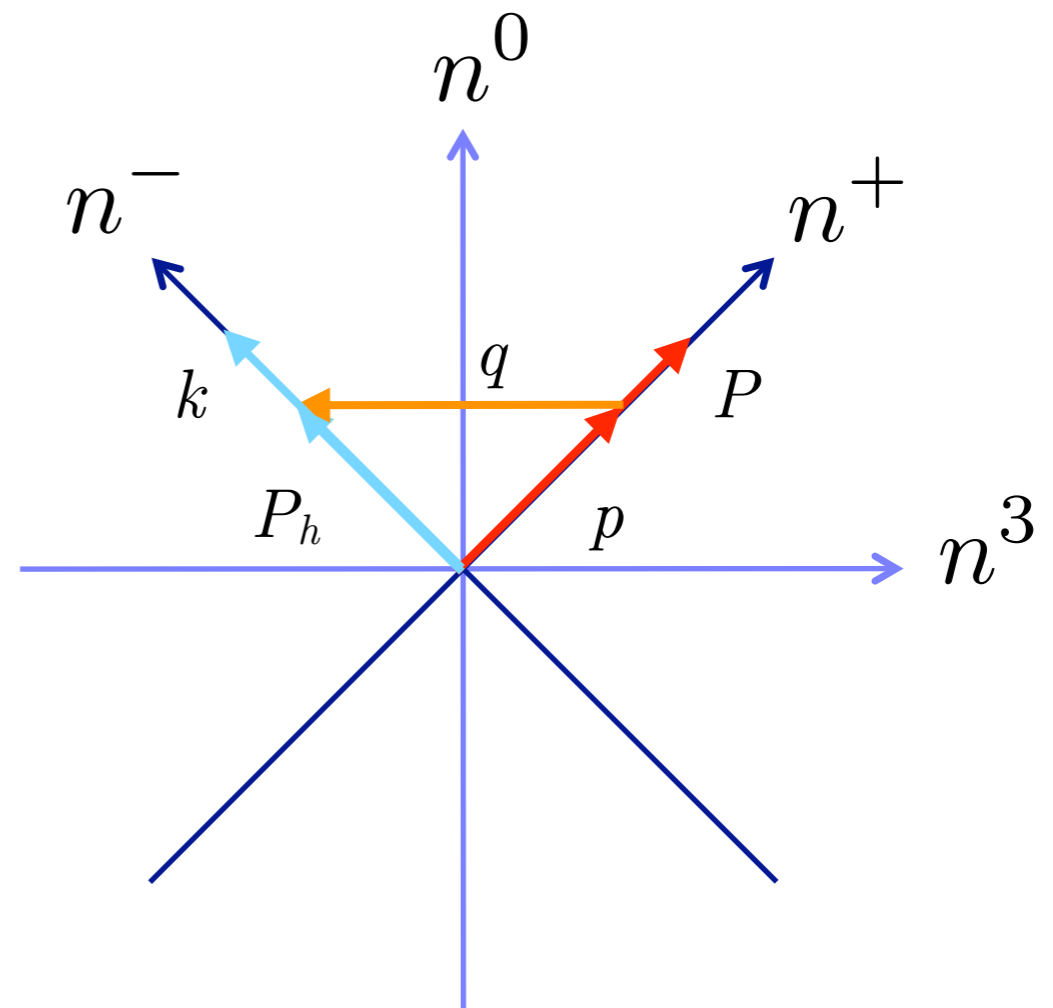
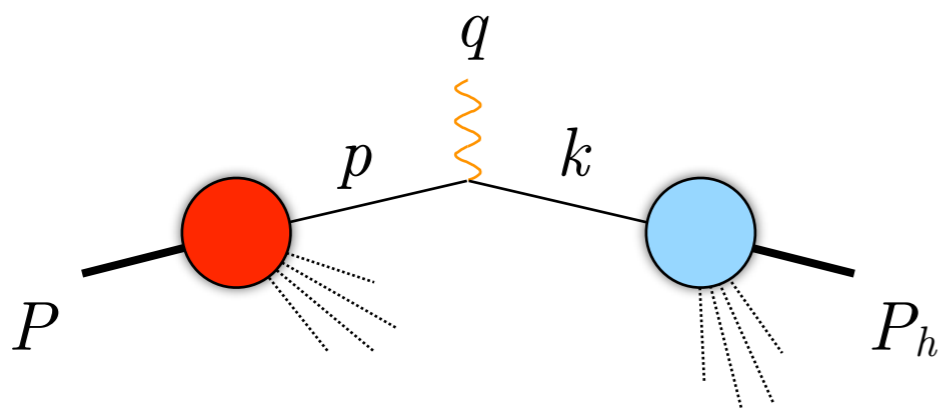

# Correlation functions in DIS

---

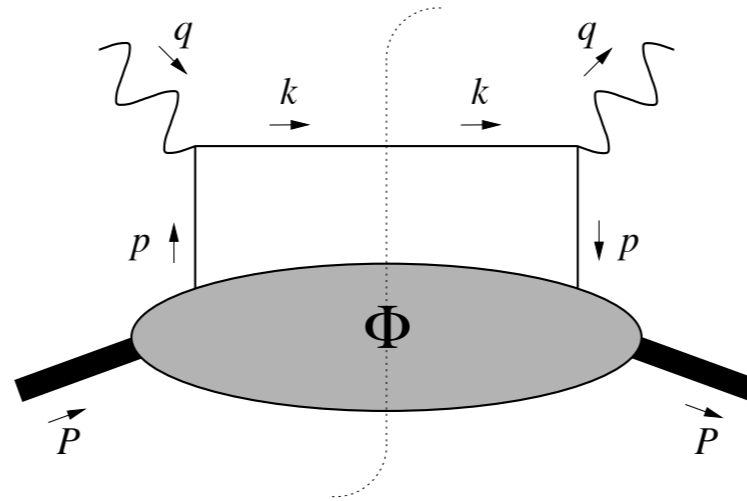

$$2MW^{\mu\nu}(q, P, S) \approx \sum_q e_q^2 \frac{1}{2} \text{Tr} [\Phi(x_B, S) \gamma^\mu \gamma^+ \gamma^\nu].$$



# Correlation functions in DIS

---

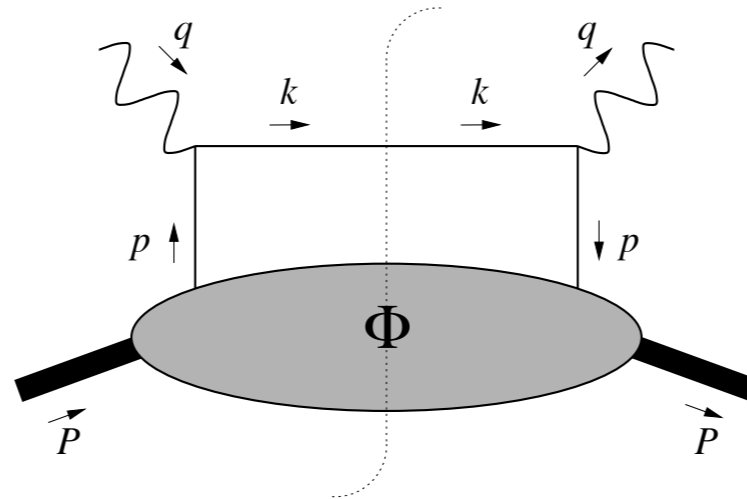

$$2MW^{\mu\nu}(q, P, S) \approx \sum_q e_q^2 \frac{1}{2} \text{Tr} [\Phi(x_B, S) \gamma^\mu \gamma^+ \gamma^\nu].$$

$$\begin{aligned} \Phi_{ij}(x, S) &= \int d^2\mathbf{p}_T dp^- \Phi_{ij}(p, P, S) \Big|_{p^+ = xP^+} \\ &= \int \frac{d\xi^-}{2\pi} e^{ip \cdot \xi} \langle P, S | \bar{\psi}_j(0) U_{[0, \xi]} \psi_i(\xi) | P, S \rangle \Big|_{\xi^+ = \xi_T = 0} \end{aligned}$$

# Correlation functions in DIS

---

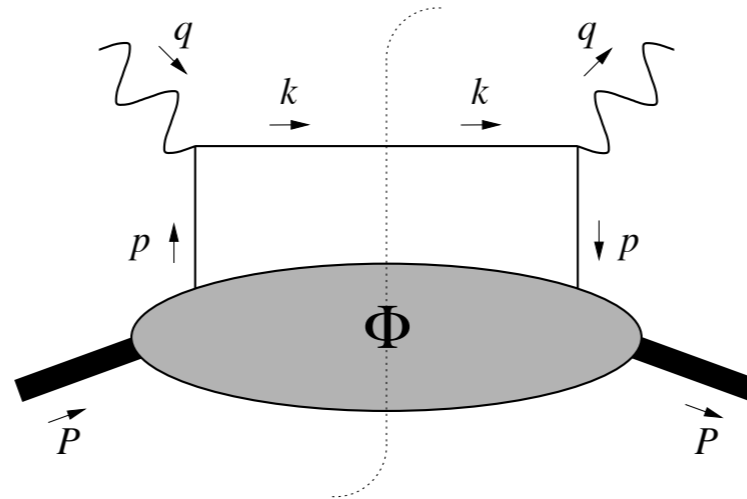

$$2MW^{\mu\nu}(q, P, S) \approx \sum_q e_q^2 \frac{1}{2} \text{Tr} [\Phi(x_B, S) \gamma^\mu \gamma^+ \gamma^\nu].$$

$$\begin{aligned} \Phi_{ij}(x, S) &= \int d^2\mathbf{p}_T dp^- \Phi_{ij}(p, P, S) \Big|_{p^+ = xP^+} \\ &= \int \frac{d\xi^-}{2\pi} e^{ip \cdot \xi} \langle P, S | \bar{\psi}_j(0) U_{[0, \xi]} \psi_i(\xi) | P, S \rangle \Big|_{\xi^+ = \xi_T = 0} \end{aligned}$$

$$\Phi_{ij}(p, P, S) = \frac{1}{(2\pi)^4} \int d^4\xi e^{ip \cdot \xi} \langle P, S | \bar{\psi}_j(0) U_{[0, \xi]} \psi_i(\xi) | P, S \rangle$$

# Correlation functions in SIDIS

---

$$2MW^{\mu\nu}(q, P, S, P_h) = 2z_h \mathcal{I} \left[ \text{Tr}(\Phi(x_B, \mathbf{p}_T, S) \gamma^\mu \Delta(z_h, \mathbf{k}_T) \gamma^\nu) \right]$$

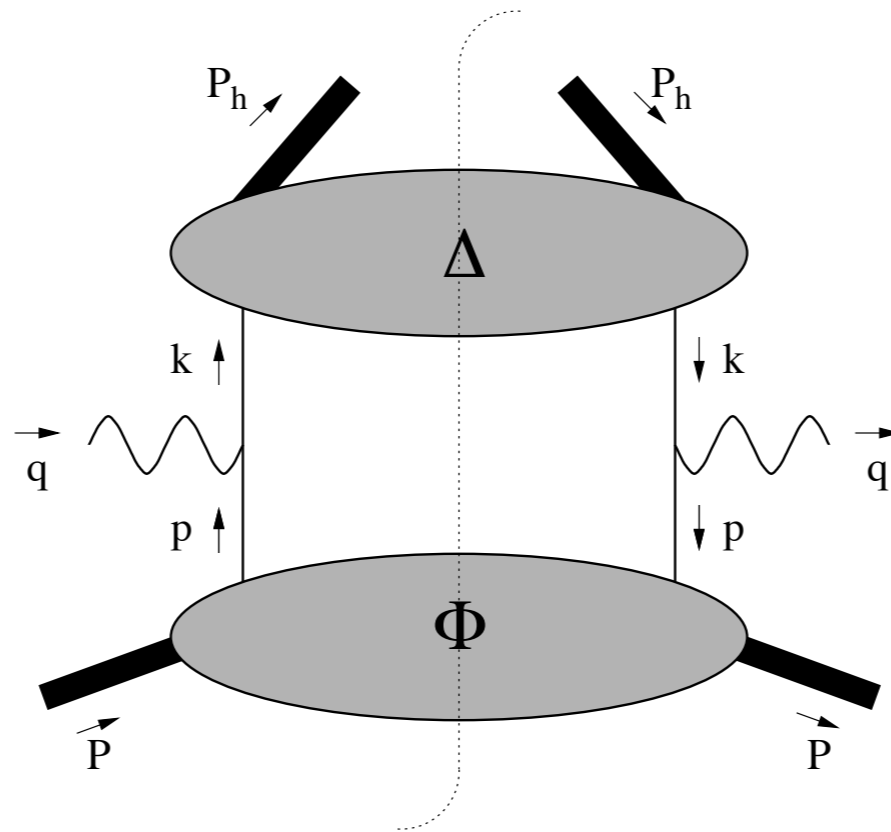

# Correlation functions in SIDIS

$$2MW^{\mu\nu}(q, P, S, P_h) = 2z_h \mathcal{I} \left[ \text{Tr}(\Phi(x_B, \mathbf{p}_T, S) \gamma^\mu \Delta(z_h, \mathbf{k}_T) \gamma^\nu) \right]$$

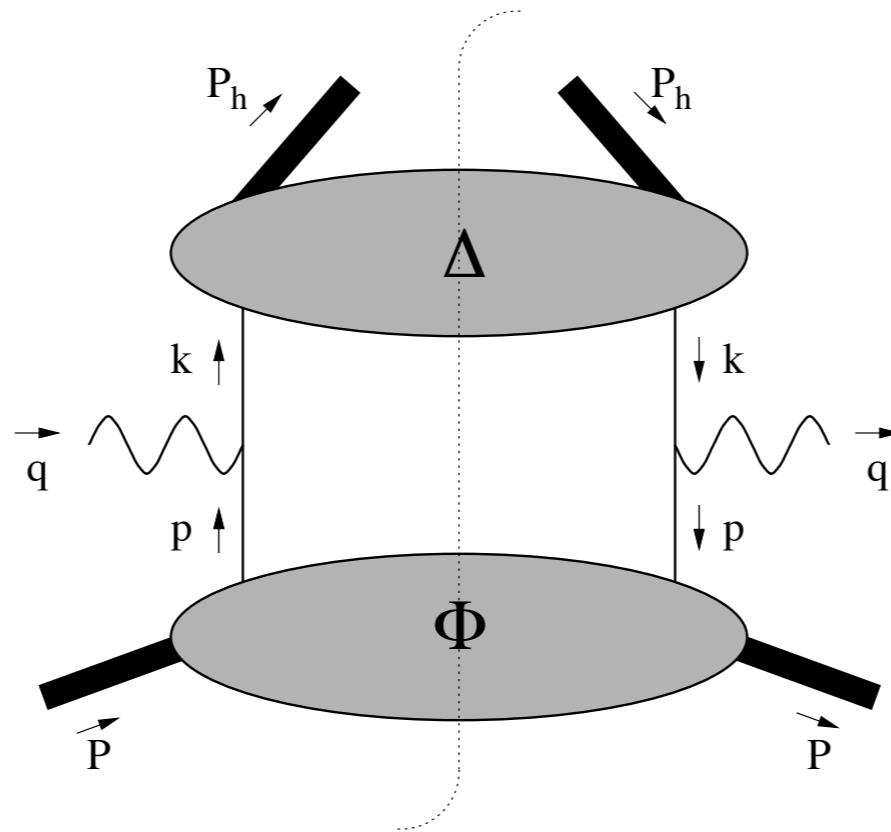

$$\mathcal{I}[\dots] \equiv \int d^2\mathbf{p}_T d^2\mathbf{k}_T \delta^{(2)}(\mathbf{p}_T + \mathbf{q}_T - \mathbf{k}_T) [\dots] = \int d^2\mathbf{p}_T d^2\mathbf{k}_T \delta^{(2)}\left(\mathbf{p}_T - \frac{\mathbf{P}_{h\perp}}{z} - \mathbf{k}_T\right) [\dots]$$

# Correlation functions in SIDIS

$$2MW^{\mu\nu}(q, P, S, P_h) = 2z_h \mathcal{I} \left[ \text{Tr}(\Phi(x_B, \mathbf{p}_T, S) \gamma^\mu \Delta(z_h, \mathbf{k}_T) \gamma^\nu) \right]$$

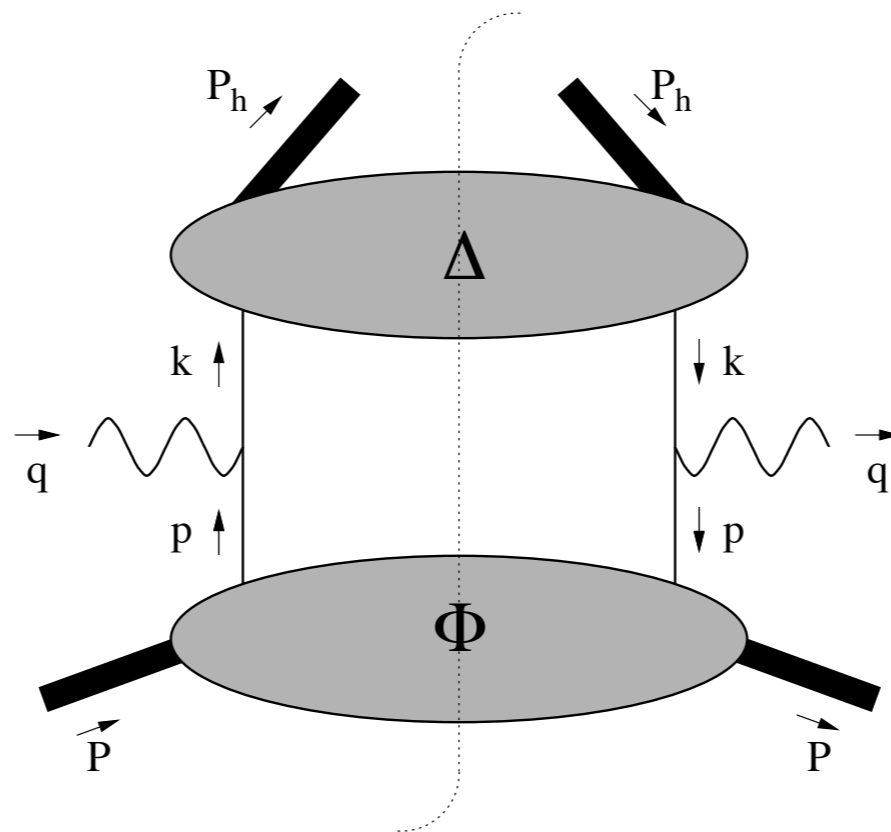

$$\mathcal{I}[\dots] \equiv \int d^2\mathbf{p}_T d^2\mathbf{k}_T \delta^{(2)}(\mathbf{p}_T + \mathbf{q}_T - \mathbf{k}_T) [\dots] = \int d^2\mathbf{p}_T d^2\mathbf{k}_T \delta^{(2)}\left(\mathbf{p}_T - \frac{\mathbf{P}_{h\perp}}{z} - \mathbf{k}_T\right) [\dots]$$

Only at low transverse momentum

$$\mathbf{P}_{h\perp}^2 \ll Q^2$$

# Integrated vs unintegrated correlators

---

$$\begin{aligned}\Phi_{ij}(x, S) &= \int d^2\mathbf{p}_T \Phi_{ij}(x, \mathbf{p}_T) \\ &= \int \frac{d\xi^-}{2\pi} e^{ip \cdot \xi} \langle P, S | \bar{\psi}_j(0) U_{[0, \xi]} \psi_i(\xi) | P, S \rangle \Big|_{\xi^+ = \xi_T = 0}\end{aligned}$$

# Integrated vs unintegrated correlators

---

$$\begin{aligned}\Phi_{ij}(x, S) &= \int d^2\mathbf{p}_T \Phi_{ij}(x, \mathbf{p}_T) \\ &= \int \frac{d\xi^-}{2\pi} e^{ip \cdot \xi} \langle P, S | \bar{\psi}_j(0) U_{[0, \xi]} \psi_i(\xi) | P, S \rangle \Big|_{\xi^+ = \xi_T = 0}\end{aligned}$$

$$\begin{aligned}\Phi_{ij}(x, \mathbf{p}_T, S) &= \int dp^- \Phi(p, P, S) \Big|_{p^+ = xP^+} \\ &= \int \frac{d\xi^- d^2\boldsymbol{\xi}_T}{(2\pi)^3} e^{ip \cdot \xi} \langle P, S | \bar{\psi}_j(0) U_{[0, \xi]} \psi_i(\xi) | P, S \rangle \Big|_{\xi^+ = 0}\end{aligned}$$

# Correlation functions

---

$p, P, S$



# Correlation functions

---

$p, P, S$

$\mathbf{1}, \gamma_5, \gamma^\mu, \gamma^\mu \gamma_5, i\sigma^{\mu\nu} \gamma_5$

# Correlation functions

---

$p, P, S$

$\mathbf{1}, \gamma_5, \gamma^\mu, \gamma^\mu \gamma_5, i\sigma^{\mu\nu} \gamma_5$

$$\sigma^{\mu\nu} \equiv \frac{i}{2} [\gamma^\mu, \gamma^\nu].$$

# Correlation functions

---

$$p, P, S$$

$$\mathbf{1}, \gamma_5, \gamma^\mu, \gamma^\mu \gamma_5, i\sigma^{\mu\nu} \gamma_5$$

$$\sigma^{\mu\nu} \equiv \frac{i}{2} [\gamma^\mu, \gamma^\nu].$$

Hermiticity:  $\Phi(p, P, S) = \gamma^0 \Phi^\dagger(p, P, S) \gamma^0,$  (1a)

parity:  $\Phi(p, P, S) = \gamma^0 \Phi(\tilde{p}, \tilde{P}, -\tilde{S}) \gamma^0$  (1b)

# Correlation functions

---

$$p, P, S$$

$$\mathbf{1}, \gamma_5, \gamma^\mu, \gamma^\mu \gamma_5, i\sigma^{\mu\nu} \gamma_5$$

$$\sigma^{\mu\nu} \equiv \frac{i}{2} [\gamma^\mu, \gamma^\nu].$$

Hermiticity:  $\Phi(p, P, S) = \gamma^0 \Phi^\dagger(p, P, S) \gamma^0,$  (1a)

parity:  $\Phi(p, P, S) = \gamma^0 \Phi(\tilde{p}, \tilde{P}, -\tilde{S}) \gamma^0$  (1b)

$$\tilde{p}^\nu = \delta^{\nu\mu} p_\mu$$

# Correlation functions

---

$$p, P, S$$

$$\mathbf{1}, \gamma_5, \gamma^\mu, \gamma^\mu \gamma_5, i\sigma^{\mu\nu} \gamma_5$$

$$\sigma^{\mu\nu} \equiv \frac{i}{2} [\gamma^\mu, \gamma^\nu].$$

$$\text{Hermiticity:} \quad \Phi(p, P, S) = \gamma^0 \Phi^\dagger(p, P, S) \gamma^0, \quad (1a)$$

$$\text{parity:} \quad \Phi(p, P, S) = \gamma^0 \Phi(\tilde{p}, \tilde{P}, -\tilde{S}) \gamma^0 \quad (1b)$$

$$\tilde{p}^\nu = \delta^{\nu\mu} p_\mu$$

For an unpolarized target, the most general decomposition is

$$\Phi(p, P) = M A_1 \mathbf{1} + A_2 \not{P} + A_3 \not{p} + \frac{A_4}{M} \sigma_{\mu\nu} P^\mu p^\nu$$

where the amplitudes  $A_i$  are real scalar functions  $A_i = A_i(p \cdot P, p^2)$  with dimension  $1/[m]^4$ .

# Parton distribution functions

---

# Parton distribution functions

---

If we keep only the leading terms in  $1/P^+$  (leading twist)

$$\Phi(p, P) \approx P^+ (A_2 + xA_3) \not{n}_+ + P^+ \frac{i}{2M} [\not{n}_+, \not{p}_T] A_4,$$

# Parton distribution functions

---

If we keep only the leading terms in  $1/P^+$  (leading twist)

$$\Phi(p, P) \approx P^+ (A_2 + xA_3) \not{n}_+ + P^+ \frac{i}{2M} [\not{n}_+, \not{p}_T] A_4,$$

$$\Phi(x, p_T) \equiv \int dp^- \Phi(p, P) = \frac{1}{2} \left\{ f_1 \not{n}_+ + ih_1^\perp \frac{[\not{p}_T, \not{n}_+]}{2M} \right\}.$$



# Parton distribution functions

---

If we keep only the leading terms in  $1/P^+$  (leading twist)

$$\Phi(p, P) \approx P^+ (A_2 + xA_3) \not{n}_+ + P^+ \frac{i}{2M} [\not{n}_+, \not{p}_T] A_4,$$

$$\Phi(x, p_T) \equiv \int dp^- \Phi(p, P) = \frac{1}{2} \left\{ f_1 \not{n}_+ + ih_1^\perp \frac{[\not{p}_T, \not{n}_+]}{2M} \right\}.$$

Here we introduced the parton distribution functions

$$f_1(x, p_T^2) = 2P^+ \int dp^- (A_2 + xA_3), \quad h_1^\perp(x, p_T^2) = 2P^+ \int dp^- (-A_4).$$

# Parton distribution functions

---

$$\Phi^{[\Gamma]} = \frac{1}{2} \text{Tr}[\Phi \Gamma]$$

$$\begin{aligned}\Phi^{[\gamma^+]} &= f_1(x, p_T^2), \\ \Phi^{[i\sigma^{\alpha+}\gamma_5]} &= -\frac{\epsilon_T^{\alpha\rho} p_{T\rho}}{M} h_1^\perp(x, p_T^2)\end{aligned}$$

# Collinear PDFs and TMDs

---

$$\Phi(x, p_T) = \frac{1}{2} \left\{ f_1 \not{n}_+ - f_{1T}^\perp \frac{\epsilon_T^{\rho\sigma} p_{T\rho} S_{T\sigma}}{M} \not{n}_+ + S_L g_{1L} \gamma_5 \not{n}_+ - g_{1T} \frac{p_T \cdot S_T}{M} \gamma_5 \not{n}_+ \right. \\ \left. + h_{1T} \frac{[\not{S}_T, \not{n}_+] \gamma_5}{2} + h_{1s}^\perp \frac{[\not{p}_T, \not{n}_+] \gamma_5}{2M} + i h_1^\perp \frac{[\not{p}_T, \not{n}_+]}{2M} \right\}$$

# Collinear PDFs and TMDs

---

$$\Phi(x) = \frac{1}{2} \left\{ f_1 \not{n}_+ + S_L g_1 \gamma_5 \not{n}_+ + h_1 \frac{[\not{S}_T, \not{n}_+] \gamma_5}{2} \right\}$$

$$\begin{aligned} \Phi(x, p_T) = \frac{1}{2} \left\{ f_1 \not{n}_+ - f_{1T}^\perp \frac{\epsilon_T^{\rho\sigma} p_{T\rho} S_{T\sigma}}{M} \not{n}_+ + S_L g_{1L} \gamma_5 \not{n}_+ - g_{1T} \frac{p_T \cdot S_T}{M} \gamma_5 \not{n}_+ \right. \\ \left. + h_{1T} \frac{[\not{S}_T, \not{n}_+] \gamma_5}{2} + h_{1s}^\perp \frac{[\not{p}_T, \not{n}_+] \gamma_5}{2M} + i h_1^\perp \frac{[\not{p}_T, \not{n}_+] \gamma_5}{2M} \right\} \end{aligned}$$

# Dirac matrices: an unusual representation

---

$$\gamma^0 = \begin{pmatrix} 0 & 0 & 1 & 0 \\ 0 & 0 & 0 & 1 \\ 1 & 0 & 0 & 0 \\ 0 & 1 & 0 & 0 \end{pmatrix},$$

$$\gamma^3 = \begin{pmatrix} 0 & 0 & -1 & 0 \\ 0 & 0 & 0 & -1 \\ 1 & 0 & 0 & 0 \\ 0 & 1 & 0 & 0 \end{pmatrix},$$

$$\gamma^1 = \begin{pmatrix} 0 & 1 & 0 & 0 \\ -1 & 0 & 0 & 0 \\ 0 & 0 & 0 & -1 \\ 0 & 0 & 1 & 0 \end{pmatrix},$$

$$\gamma^2 = \begin{pmatrix} 0 & i & 0 & 0 \\ i & 0 & 0 & 0 \\ 0 & 0 & 0 & -i \\ 0 & 0 & -i & 0 \end{pmatrix},$$

$$\gamma_5 = \begin{pmatrix} 1 & 0 & 0 & 0 \\ 0 & -1 & 0 & 0 \\ 0 & 0 & -1 & 0 \\ 0 & 0 & 0 & 1 \end{pmatrix}$$

# Good/Bad and Right/Left projectors

---

$$\mathcal{P}^+ = \gamma^- \gamma^+ / 2,$$

$$\mathcal{P}^- = \gamma^+ \gamma^- / 2,$$

$$\mathcal{P}_R = (1 + \gamma_5) / 2,$$

$$\mathcal{P}_L = (1 - \gamma_5) / 2$$

# Good/Bad and Right/Left projectors

---

$$\mathcal{P}^+ = \gamma^- \gamma^+ / 2,$$

$$\mathcal{P}^- = \gamma^+ \gamma^- / 2,$$

$$\mathcal{P}_R = (1 + \gamma_5) / 2,$$

$$\mathcal{P}_L = (1 - \gamma_5) / 2$$

$$\mathcal{P}_R \mathcal{P}^+ = \begin{pmatrix} 1 & 0 & 0 & 0 \\ 0 & 0 & 0 & 0 \\ 0 & 0 & 0 & 0 \\ 0 & 0 & 0 & 0 \end{pmatrix},$$

$$\mathcal{P}_L \mathcal{P}^+ = \begin{pmatrix} 0 & 0 & 0 & 0 \\ 0 & 1 & 0 & 0 \\ 0 & 0 & 0 & 0 \\ 0 & 0 & 0 & 0 \end{pmatrix},$$

$$\mathcal{P}_R \mathcal{P}^- = \begin{pmatrix} 0 & 0 & 0 & 0 \\ 0 & 0 & 0 & 0 \\ 0 & 0 & 0 & 0 \\ 0 & 0 & 0 & 1 \end{pmatrix},$$

$$\mathcal{P}_L \mathcal{P}^- = \begin{pmatrix} 0 & 0 & 0 & 0 \\ 0 & 0 & 0 & 0 \\ 0 & 0 & 1 & 0 \\ 0 & 0 & 0 & 0 \end{pmatrix}$$

# Good/Bad and Right/Left projectors

---

$$\mathcal{P}^+ = \gamma^- \gamma^+ / 2,$$

$$\mathcal{P}^- = \gamma^+ \gamma^- / 2,$$

$$\mathcal{P}_R = (1 + \gamma_5) / 2,$$

$$\mathcal{P}_L = (1 - \gamma_5) / 2$$

**Good**

$$\mathcal{P}_R \mathcal{P}^+ = \begin{pmatrix} 1 & 0 & 0 & 0 \\ 0 & 0 & 0 & 0 \\ 0 & 0 & 0 & 0 \\ 0 & 0 & 0 & 0 \end{pmatrix},$$

$$\mathcal{P}_L \mathcal{P}^+ = \begin{pmatrix} 0 & 0 & 0 & 0 \\ 0 & 1 & 0 & 0 \\ 0 & 0 & 0 & 0 \\ 0 & 0 & 0 & 0 \end{pmatrix},$$

$$\mathcal{P}_R \mathcal{P}^- = \begin{pmatrix} 0 & 0 & 0 & 0 \\ 0 & 0 & 0 & 0 \\ 0 & 0 & 0 & 0 \\ 0 & 0 & 0 & 1 \end{pmatrix},$$

$$\mathcal{P}_L \mathcal{P}^- = \begin{pmatrix} 0 & 0 & 0 & 0 \\ 0 & 0 & 0 & 0 \\ 0 & 0 & 1 & 0 \\ 0 & 0 & 0 & 0 \end{pmatrix}$$



# The correlator as probability density matrix

---

$$\Phi\gamma^0 = \begin{pmatrix} f_1 & i\frac{(p_x+ip_y)}{M}h_1^\perp & 0 & 0 \\ -i\frac{(p_x-ip_y)}{M}h_1^\perp & f_1 & 0 & 0 \\ 0 & 0 & 0 & 0 \\ 0 & 0 & 0 & 0 \end{pmatrix} \sim \psi_i |P\rangle\langle P| \psi_j^\dagger$$

# The correlator as probability density matrix

---

$$\Phi\gamma^0 = \begin{pmatrix} f_1 & i\frac{(p_x+ip_y)}{M}h_1^\perp & 0 & 0 \\ -i\frac{(p_x-ip_y)}{M}h_1^\perp & f_1 & 0 & 0 \\ 0 & 0 & 0 & 0 \\ 0 & 0 & 0 & 0 \end{pmatrix} \sim \psi_i |P\rangle\langle P| \psi_j^\dagger$$

# The correlator as probability density matrix

$$\Phi\gamma^0 = \begin{array}{c} \text{R} \\ \text{L} \end{array} \begin{array}{c} \text{R} \\ \text{L} \end{array} \left( \begin{array}{cccc} f_1 & i \frac{(p_x + ip_y)}{M} h_1^\perp & 0 & 0 \\ -i \frac{(p_x - ip_y)}{M} h_1^\perp & f_1 & 0 & 0 \\ 0 & 0 & 0 & 0 \\ 0 & 0 & 0 & 0 \end{array} \right) \sim \psi_i |P\rangle \langle P| \psi_j^\dagger$$

# The correlator as probability density matrix

$$\Phi\gamma^0 = \begin{array}{c} \text{R} \\ \text{L} \end{array} \begin{array}{c} \text{R} \\ \text{L} \end{array} \left( \begin{array}{cccc} f_1 & i \frac{(p_x + ip_y)}{M} h_1^\perp & 0 & 0 \\ -i \frac{(p_x - ip_y)}{M} h_1^\perp & f_1 & 0 & 0 \\ 0 & 0 & 0 & 0 \\ 0 & 0 & 0 & 0 \end{array} \right) \sim \psi_i |P\rangle \langle P| \psi_j^\dagger$$

- Probabilistic interpretation

# The correlator as probability density matrix

$$\Phi\gamma^0 = \begin{array}{c} \text{R} \\ \text{L} \end{array} \begin{array}{c} \text{R} \\ \text{L} \end{array} \left( \begin{array}{cccc} f_1 & i \frac{(p_x + ip_y)}{M} h_1^\perp & 0 & 0 \\ -i \frac{(p_x - ip_y)}{M} h_1^\perp & f_1 & 0 & 0 \\ 0 & 0 & 0 & 0 \\ 0 & 0 & 0 & 0 \end{array} \right) \sim \psi_i |P\rangle \langle P| \psi_j^\dagger$$

- Probabilistic interpretation
- Positivity bounds

# The correlator as probability density matrix

$$\Phi\gamma^0 = \begin{pmatrix} \begin{matrix} \text{R} \\ \text{L} \end{matrix} & \begin{matrix} \text{R} & \text{L} \end{matrix} \\ \begin{matrix} f_1 & i \frac{(p_x + ip_y)}{M} h_1^\perp \\ -i \frac{(p_x - ip_y)}{M} h_1^\perp & f_1 \end{matrix} & \begin{matrix} 0 & 0 \\ 0 & 0 \end{matrix} \\ 0 & 0 \\ 0 & 0 \end{pmatrix} \sim \psi_i |P\rangle \langle P| \psi_j^\dagger$$

- Probabilistic interpretation
- Positivity bounds
- Need of orbital angular momentum

# In $x$ -transversity basis

---

$$\Phi \gamma^0 = \begin{pmatrix}
 \begin{matrix} \uparrow \\ \downarrow \end{matrix} & \begin{matrix} \uparrow & \downarrow \end{matrix} & & \\
 \begin{matrix} f_1 - \frac{p_y}{M} h_1^\perp & i \frac{p_x}{M} h_1^\perp \\ -i \frac{p_x}{M} h_1^\perp & f_1 + \frac{p_y}{M} h_1^\perp \end{matrix} & \begin{matrix} 0 & 0 \\ 0 & 0 \end{matrix} & & \\
 0 & 0 & 0 & 0 \\
 0 & 0 & 0 & 0
 \end{pmatrix} \sim \psi_i |P\rangle \langle P| \psi_j^\dagger$$

# TMDs and their probabilistic interpretation

---



# TMDs and their probabilistic interpretation

---

quark pol.

	U	L	T
nucleon pol. U	$f_1$		$h_1^\perp$
L		$g_{1L}$	$h_{1L}^\perp$
T	$f_{1T}^\perp$	$g_{1T}$	$h_1, h_{1T}^\perp$

Twist-2 TMDs

TMDs in black survive transverse-momentum integration  
TMDs in red are T-odd

# TMDs and their probabilistic interpretation

---

$$f_1 = \text{circle with blue dot}$$

$$g_1 = \text{circle with black dot and blue dot} - \text{circle with black dot and blue dot with red X}$$

$$h_1 = \text{circle with blue dot and red arrow pointing right} - \text{circle with blue dot and red arrow pointing left}$$

# TMDs and their probabilistic interpretation

---

$$f_1 = \text{circle with blue dot}$$

$$g_1 = \text{circle with black dot and blue dot with red cross} - \text{circle with black dot and blue dot with red dot}$$

$$h_1 = \text{circle with blue dot and red arrow pointing right} - \text{circle with blue dot and red arrow pointing left}$$

$$f_{1T}^\perp = \text{circle with blue dot and vertical dashed arrow pointing down} - \text{circle with blue dot and vertical dashed arrow pointing up}$$

$$h_{1T}^\perp = \text{circle with blue dot, red arrow pointing right, and vertical dashed arrow pointing down} - \text{circle with blue dot, red arrow pointing right, and vertical dashed arrow pointing up}$$

$$g_{1T} = \text{circle with blue dot, red dot, and horizontal dashed arrow pointing right} - \text{circle with blue dot, red dot, and horizontal dashed arrow pointing left}$$

$$h_{1L}^\perp = \text{circle with blue dot, red arrow pointing right, and black dot} - \text{circle with blue dot, red arrow pointing left, and black dot}$$

$$h_{1T}^\perp = \text{circle with blue dot, red arrow pointing right, and horizontal dashed arrow pointing right} - \text{circle with blue dot, red arrow pointing left, and horizontal dashed arrow pointing left}$$

# A short note on $g_T$

---

$$\begin{aligned}\Phi(x, S_x)\gamma^0 &= \frac{1}{2} \left\{ f_1\gamma^- + S_L g_1\gamma_5\gamma^- - h_1 S_T\gamma_5\gamma^1\gamma^- \right\} \gamma^0 \\ &+ \frac{M}{2P^+} \left\{ e - g_T S_T\gamma_5\gamma^1 + h_L S_L \frac{[\gamma^-, \gamma^+]\gamma_5}{2} \right\} \gamma^0\end{aligned}$$

# A short note on $g_T$

---

$$\begin{aligned}\Phi(x, S_x)\gamma^0 &= \frac{1}{2} \left\{ f_1\gamma^- + S_L g_1\gamma_5\gamma^- - h_1 S_T\gamma_5\gamma^1\gamma^- \right\} \gamma^0 \\ &+ \frac{M}{2P^+} \left\{ e - g_T S_T\gamma_5\gamma^1 + h_L S_L \frac{[\gamma^-, \gamma^+]\gamma_5}{2} \right\} \gamma^0\end{aligned}$$

$$\gamma_5\gamma^-\gamma^0 = \sqrt{2} \begin{pmatrix} \sigma^3 & 0 \\ 0 & 0 \end{pmatrix}$$

$$\gamma_5\gamma^1\gamma^-\gamma^0 = \sqrt{2} \begin{pmatrix} \sigma^1 & 0 \\ 0 & 0 \end{pmatrix}$$

$$\gamma_5\gamma^1\gamma^0 = \sqrt{2} \begin{pmatrix} 0 & \sigma^1 \\ \sigma^1 & 0 \end{pmatrix}$$

# A short note on $g_T$

---

$$\begin{aligned}\Phi(x, S_x)\gamma^0 &= \frac{1}{2} \left\{ f_1\gamma^- + S_L g_1\gamma_5\gamma^- - h_1 S_T\gamma_5\gamma^1\gamma^- \right\} \gamma^0 \\ &+ \frac{M}{2P^+} \left\{ e - g_T S_T\gamma_5\gamma^1 + h_L S_L \frac{[\gamma^-, \gamma^+]\gamma_5}{2} \right\} \gamma^0\end{aligned}$$

$$\gamma_5\gamma^-\gamma^0 = \sqrt{2} \begin{pmatrix} \sigma^3 & 0 \\ 0 & 0 \end{pmatrix}$$

$$\gamma_5\gamma^1\gamma^-\gamma^0 = \sqrt{2} \begin{pmatrix} \sigma^1 & 0 \\ 0 & 0 \end{pmatrix}$$

$$\gamma_5\gamma^1\gamma^0 = \sqrt{2} \begin{pmatrix} 0 & \sigma^1 \\ \sigma^1 & 0 \end{pmatrix}$$

My impression is that it's relevant for the Bakker-Trueman-Leader transverse angular momentum sum-rule

# A short note on $g_T$

---

$$\begin{aligned}\Phi(x, S_x)\gamma^0 &= \frac{1}{2} \left\{ f_1 \gamma^- + S_L g_1 \gamma_5 \gamma^- - h_1 S_T \gamma_5 \gamma^1 \gamma^- \right\} \gamma^0 \\ &+ \frac{M}{2P^+} \left\{ e - g_T S_T \gamma_5 \gamma^1 + h_L S_L \frac{[\gamma^-, \gamma^+] \gamma_5}{2} \right\} \gamma^0\end{aligned}$$

$$\gamma_5 \gamma^- \gamma^0 = \sqrt{2} \begin{pmatrix} \sigma^3 & 0 \\ 0 & 0 \end{pmatrix}$$

$$\gamma_5 \gamma^1 \gamma^- \gamma^0 = \sqrt{2} \begin{pmatrix} \sigma^1 & 0 \\ 0 & 0 \end{pmatrix}$$

$$\gamma_5 \gamma^1 \gamma^0 = \sqrt{2} \begin{pmatrix} 0 & \sigma^1 \\ \sigma^1 & 0 \end{pmatrix}$$

My impression is that it's relevant for the Bakker-Trueman-Leader transverse angular momentum sum-rule

<http://www.ts.infn.it/eventi/transversitySR/>

# Unpolarized sector

---

$$F_{UU,T} = \mathcal{C}[f_1 D_1],$$

$$F_{UU,L} = \mathcal{O}\left(\frac{M^2}{Q^2}, \frac{q_T^2}{Q^2}\right),$$

$$F_{UU}^{\cos \phi_h} = \frac{2M}{Q} \mathcal{C} \left[ -\frac{\hat{\mathbf{h}} \cdot \mathbf{k}_T}{M_h} \left( x h H_1^\perp + \frac{M_h}{M} f_1 \frac{\tilde{D}^\perp}{z} \right) - \frac{\hat{\mathbf{h}} \cdot \mathbf{p}_T}{M} \left( x f^\perp D_1 + \frac{M_h}{M} h_1^\perp \frac{\tilde{H}}{z} \right) \right],$$

$$F_{UU}^{\cos 2\phi_h} = \mathcal{C} \left[ -\frac{2 (\hat{\mathbf{h}} \cdot \mathbf{k}_T) (\hat{\mathbf{h}} \cdot \mathbf{p}_T) - \mathbf{k}_T \cdot \mathbf{p}_T}{M M_h} h_1^\perp H_1^\perp \right],$$

$$\mathcal{C}[w f D] = \sum_a x e_a^2 \int d^2 \mathbf{p}_T d^2 \mathbf{k}_T \delta^{(2)}(\mathbf{p}_T - \mathbf{k}_T - \mathbf{P}_{h\perp}/z) w(\mathbf{p}_T, \mathbf{k}_T) f^a(x, p_T^2) D^a(z, k_T^2),$$



# Longitudinally polarized beam or/and target

---

$$F_{LU}^{\sin \phi_h} = \frac{2M}{Q} \mathcal{C} \left[ -\frac{\hat{\mathbf{h}} \cdot \mathbf{k}_T}{M_h} \left( x e H_1^\perp + \frac{M_h}{M} f_1 \frac{\tilde{G}^\perp}{z} \right) + \frac{\hat{\mathbf{h}} \cdot \mathbf{p}_T}{M} \left( x g^\perp D_1 + \frac{M_h}{M} h_1^\perp \frac{\tilde{E}}{z} \right) \right],$$

$$F_{UL}^{\sin \phi_h} = \frac{2M}{Q} \mathcal{C} \left[ -\frac{\hat{\mathbf{h}} \cdot \mathbf{k}_T}{M_h} \left( x h_L H_1^\perp + \frac{M_h}{M} g_{1L} \frac{\tilde{G}^\perp}{z} \right) + \frac{\hat{\mathbf{h}} \cdot \mathbf{p}_T}{M} \left( x f_L^\perp D_1 - \frac{M_h}{M} h_{1L}^\perp \frac{\tilde{H}}{z} \right) \right],$$

$$F_{UL}^{\sin 2\phi_h} = \mathcal{C} \left[ -\frac{2 (\hat{\mathbf{h}} \cdot \mathbf{k}_T) (\hat{\mathbf{h}} \cdot \mathbf{p}_T) - \mathbf{k}_T \cdot \mathbf{p}_T}{M M_h} h_{1L}^\perp H_1^\perp \right],$$

$$F_{LL} = \mathcal{C} [g_{1L} D_1],$$

$$F_{LL}^{\cos \phi_h} = \frac{2M}{Q} \mathcal{C} \left[ \frac{\hat{\mathbf{h}} \cdot \mathbf{k}_T}{M_h} \left( x e_L H_1^\perp - \frac{M_h}{M} g_{1L} \frac{\tilde{D}^\perp}{z} \right) - \frac{\hat{\mathbf{h}} \cdot \mathbf{p}_T}{M} \left( x g_L^\perp D_1 + \frac{M_h}{M} h_{1L}^\perp \frac{\tilde{E}}{z} \right) \right],$$

# Transversely polarized beam

---

$$F_{UT,T}^{\sin(\phi_h - \phi_S)} = \mathcal{C} \left[ -\frac{\hat{\mathbf{h}} \cdot \mathbf{p}_T}{M} f_{1T}^\perp D_1 \right],$$

$$F_{UT,L}^{\sin(\phi_h - \phi_S)} = \mathcal{O} \left( \frac{M^2}{Q^2}, \frac{q_T^2}{Q^2} \right),$$

$$F_{UT}^{\sin(\phi_h + \phi_S)} = \mathcal{C} \left[ -\frac{\hat{\mathbf{h}} \cdot \mathbf{k}_T}{M_h} h_1 H_1^\perp \right],$$

$$F_{UT}^{\sin(3\phi_h - \phi_S)} = \mathcal{C} \left[ \frac{2(\hat{\mathbf{h}} \cdot \mathbf{p}_T)(\mathbf{p}_T \cdot \mathbf{k}_T) + \mathbf{p}_T^2(\hat{\mathbf{h}} \cdot \mathbf{k}_T) - 4(\hat{\mathbf{h}} \cdot \mathbf{p}_T)^2(\hat{\mathbf{h}} \cdot \mathbf{k}_T)}{2M^2 M_h} h_{1T}^\perp H_1^\perp \right],$$

$$F_{UT}^{\sin \phi_S} = \frac{2M}{Q} \mathcal{C} \left\{ \left( x f_T D_1 - \frac{M_h}{M} h_1 \frac{\tilde{H}}{z} \right) - \frac{\mathbf{k}_T \cdot \mathbf{p}_T}{2M M_h} \left[ \left( x h_T H_1^\perp + \frac{M_h}{M} g_{1T} \frac{\tilde{G}^\perp}{z} \right) - \left( x h_T^\perp H_1^\perp - \frac{M_h}{M} f_{1T}^\perp \frac{\tilde{D}^\perp}{z} \right) \right] \right\},$$

$$F_{UT}^{\sin(2\phi_h - \phi_S)} = \frac{2M}{Q} \mathcal{C} \left\{ \frac{2(\hat{\mathbf{h}} \cdot \mathbf{p}_T)^2 - \mathbf{p}_T^2}{2M^2} \left( x f_T^\perp D_1 - \frac{M_h}{M} h_{1T}^\perp \frac{\tilde{H}}{z} \right) - \frac{2(\hat{\mathbf{h}} \cdot \mathbf{k}_T)(\hat{\mathbf{h}} \cdot \mathbf{p}_T) - \mathbf{k}_T \cdot \mathbf{p}_T}{2M M_h} \left[ \left( x h_T H_1^\perp + \frac{M_h}{M} g_{1T} \frac{\tilde{G}^\perp}{z} \right) + \left( x h_T^\perp H_1^\perp - \frac{M_h}{M} f_{1T}^\perp \frac{\tilde{D}^\perp}{z} \right) \right] \right\},$$

# Trasversely pol. target and long. pol. beam

---

$$F_{LT}^{\cos(\phi_h - \phi_S)} = \mathcal{C} \left[ \frac{\hat{\mathbf{h}} \cdot \mathbf{p}_T}{M} g_{1T} D_1 \right],$$

$$F_{LT}^{\cos \phi_S} = \frac{2M}{Q} \mathcal{C} \left\{ - \left( x g_T D_1 + \frac{M_h}{M} h_1 \frac{\tilde{E}}{z} \right) + \frac{\mathbf{k}_T \cdot \mathbf{p}_T}{2MM_h} \left[ \left( x e_T H_1^\perp - \frac{M_h}{M} g_{1T} \frac{\tilde{D}^\perp}{z} \right) + \left( x e_T^\perp H_1^\perp + \frac{M_h}{M} f_{1T}^\perp \frac{\tilde{G}^\perp}{z} \right) \right] \right\},$$

$$F_{LT}^{\cos(2\phi_h - \phi_S)} = \frac{2M}{Q} \mathcal{C} \left\{ - \frac{2(\hat{\mathbf{h}} \cdot \mathbf{p}_T)^2 - \mathbf{p}_T^2}{2M^2} \left( x g_T^\perp D_1 + \frac{M_h}{M} h_{1T}^\perp \frac{\tilde{E}}{z} \right) + \frac{2(\hat{\mathbf{h}} \cdot \mathbf{k}_T)(\hat{\mathbf{h}} \cdot \mathbf{p}_T) - \mathbf{k}_T \cdot \mathbf{p}_T}{2MM_h} \left[ \left( x e_T H_1^\perp - \frac{M_h}{M} g_{1T} \frac{\tilde{D}^\perp}{z} \right) - \left( x e_T^\perp H_1^\perp + \frac{M_h}{M} f_{1T}^\perp \frac{\tilde{G}^\perp}{z} \right) \right] \right\}$$

# The gauge link

---

# Need of a gauge link

---

$$\Phi_{ij}(p, P, S) = \frac{1}{(2\pi)^4} \int d^4\xi e^{ip \cdot \xi} \langle P, S | \bar{\psi}_j(0) \psi_i(\xi) | P, S \rangle$$

# Need of a gauge link

---

$$\Phi_{ij}(p, P, S) = \frac{1}{(2\pi)^4} \int d^4\xi e^{ip \cdot \xi} \langle P, S | \bar{\psi}_j(0) \psi_i(\xi) | P, S \rangle$$

$$\psi(\xi) \rightarrow e^{i\alpha(\xi)} \psi(\xi)$$

# Need of a gauge link

---

$$\Phi_{ij}(p, P, S) = \frac{1}{(2\pi)^4} \int d^4\xi e^{ip \cdot \xi} \langle P, S | \bar{\psi}_j(0) \psi_i(\xi) | P, S \rangle$$

$$\psi(\xi) \rightarrow e^{i\alpha(\xi)} \psi(\xi)$$

$$\Phi_{ij}(p, P, S) = \frac{1}{(2\pi)^4} \int d^4\xi e^{ip \cdot \xi} \langle P, S | \bar{\psi}_j(0) U_{[0, \xi]} \psi_i(\xi) | P, S \rangle$$

# Need of a gauge link

---

$$\Phi_{ij}(p, P, S) = \frac{1}{(2\pi)^4} \int d^4\xi e^{ip \cdot \xi} \langle P, S | \bar{\psi}_j(0) \psi_i(\xi) | P, S \rangle$$

$$\psi(\xi) \rightarrow e^{i\alpha(\xi)} \psi(\xi)$$

$$\Phi_{ij}(p, P, S) = \frac{1}{(2\pi)^4} \int d^4\xi e^{ip \cdot \xi} \langle P, S | \bar{\psi}_j(0) U_{[0, \xi]} \psi_i(\xi) | P, S \rangle$$

$$U(\xi_1, \xi_2) \rightarrow e^{i\alpha(\xi_1)} U(\xi_1, \xi_2) e^{-i\alpha(\xi_2)}.$$



# Need of a gauge link

---

$$\Phi_{ij}(p, P, S) = \frac{1}{(2\pi)^4} \int d^4\xi e^{ip \cdot \xi} \langle P, S | \bar{\psi}_j(0) \psi_i(\xi) | P, S \rangle$$

$$\psi(\xi) \rightarrow e^{i\alpha(\xi)} \psi(\xi)$$

$$\Phi_{ij}(p, P, S) = \frac{1}{(2\pi)^4} \int d^4\xi e^{ip \cdot \xi} \langle P, S | \bar{\psi}_j(0) U_{[0,\xi]} \psi_i(\xi) | P, S \rangle$$

$$U(\xi_1, \xi_2) \rightarrow e^{i\alpha(\xi_1)} U(\xi_1, \xi_2) e^{-i\alpha(\xi_2)}.$$

$$U_{[a,b]} = \mathcal{P} \exp \left[ -ig \int_a^b d\eta^\mu A_\mu(\eta) \right]$$

# Birth of the gauge link

---

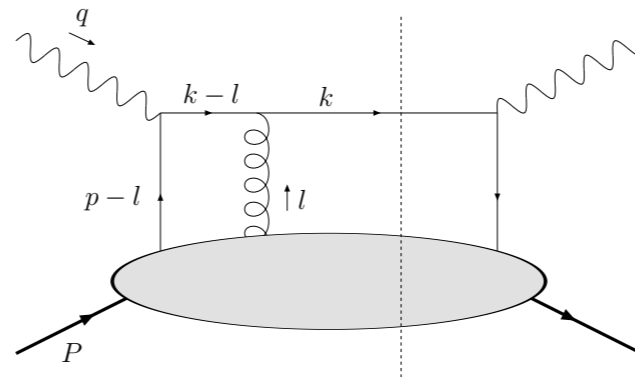

(a)

$$2MW_{\mu\nu}^{(a)} \sim \langle P, S | \bar{\psi}(0) \gamma_\mu \gamma^+ \gamma_\alpha \frac{\not{k} - \not{l} + m}{(k-l)^2 - m^2 + i\epsilon} \gamma_\nu g A^\alpha(\eta) \psi(\xi) | P, S \rangle \Big|_{\eta^+ = 0}$$

# Birth of the gauge link

---

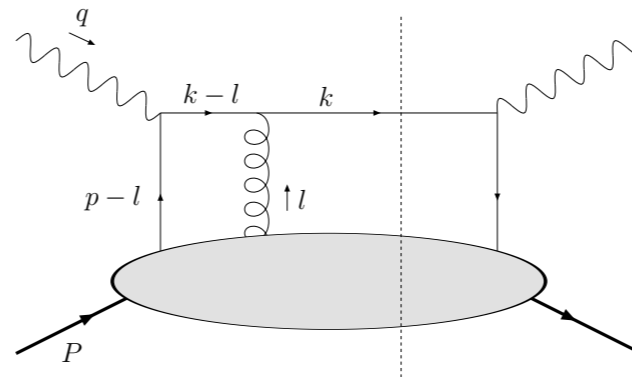

(a)

$$2MW_{\mu\nu}^{(a)} \sim \langle P, S | \bar{\psi}(0) \gamma_\mu \gamma^+ \gamma_\alpha \frac{\not{k} - \not{l} + m}{(k-l)^2 - m^2 + i\epsilon} \gamma_\nu g A^\alpha(\eta) \psi(\xi) | P, S \rangle \Big|_{\eta^+ = 0}$$

$$i \frac{\not{k} - \not{l} + m}{(k-l)^2 - m^2 + i\epsilon} \approx i \frac{k^- \gamma^+}{-2l^+ k^- + i\epsilon} \approx \frac{i}{2} \frac{\gamma^+}{-l^+ + i\epsilon}$$

# Birth of the gauge link

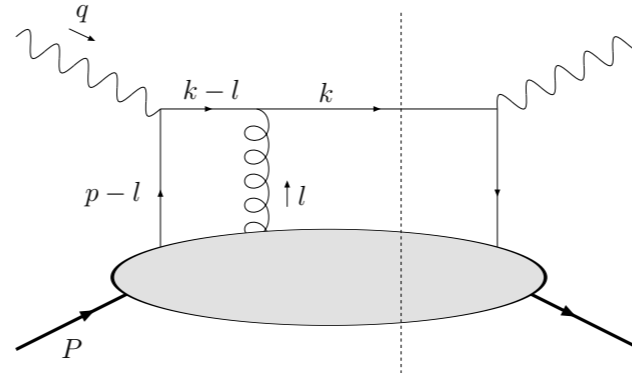

(a)

$$2MW_{\mu\nu}^{(a)} \sim \langle P, S | \bar{\psi}(0) \gamma_\mu \gamma^+ \gamma_\alpha \frac{\not{k} - \not{l} + m}{(k-l)^2 - m^2 + i\epsilon} \gamma_\nu g A^\alpha(\eta) \psi(\xi) | P, S \rangle \Big|_{\eta^+=0}$$

$$i \frac{\not{k} - \not{l} + m}{(k-l)^2 - m^2 + i\epsilon} \approx i \frac{k^- \gamma^+}{-2l^+ k^- + i\epsilon} \approx \frac{i}{2} \frac{\gamma^+}{-l^+ + i\epsilon}$$

$$2MW_{\mu\nu}^{(a)} \sim \langle P, S | \bar{\psi}(0) \gamma_\mu \gamma^+ \frac{A^+(\eta)}{-l^+ + i\epsilon} \gamma_\nu \psi(\xi) | P, S \rangle \Big|_{\eta^+=0}$$

# Birth of the gauge link

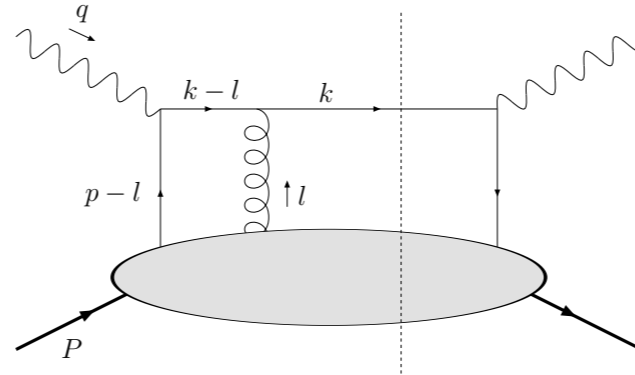

(a)

$$2MW_{\mu\nu}^{(a)} \sim \langle P, S | \bar{\psi}(0) \gamma_\mu \gamma^+ \gamma_\alpha \frac{\not{k} - \not{l} + m}{(k-l)^2 - m^2 + i\epsilon} \gamma_\nu g A^\alpha(\eta) \psi(\xi) | P, S \rangle \Big|_{\eta^+ = 0}$$

$$i \frac{\not{k} - \not{l} + m}{(k-l)^2 - m^2 + i\epsilon} \approx i \frac{k^- \gamma^+}{-2l^+ k^- + i\epsilon} \approx \frac{i}{2} \frac{\gamma^+}{-l^+ + i\epsilon}$$

$$2MW_{\mu\nu}^{(a)} \sim \langle P, S | \bar{\psi}(0) \gamma_\mu^+ \frac{-\gamma^+}{2} \gamma_\nu (ig) \frac{A^+(\eta)}{-l^+ + i\epsilon} \psi(\xi) | P, S \rangle \Big|_{\eta^+ = 0}$$

$$2MW_{\mu\nu}^{(a)} \sim \langle P, S | \bar{\psi}(0) \gamma_\mu \gamma^+ \gamma_\nu (-ig) \int_{\infty^-}^{\xi^-} d\eta^- A^+(\eta) \psi(\xi) | P, S \rangle \Big|_{\eta^+ = 0; \boldsymbol{\eta}_T = \boldsymbol{\xi}_T}$$

# Birth of the gauge link

---

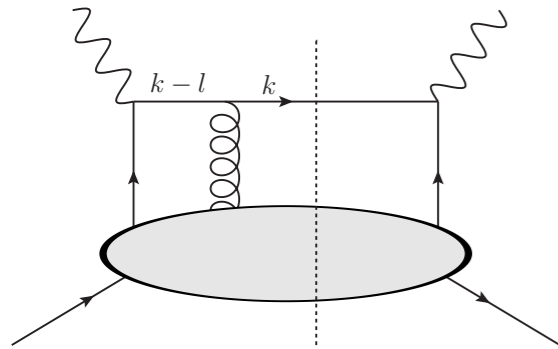

$$2MW_{\mu\nu}^{(a)} \sim \langle P, S | \bar{\psi}(0) \gamma_\mu \gamma^+ \gamma_\nu (-ig) \int_{\infty^-}^{\xi^-} d\eta^- A^+(\eta) \psi(\xi) | P, S \rangle \Big|_{\eta^+=0; \eta_T=\xi_T}$$

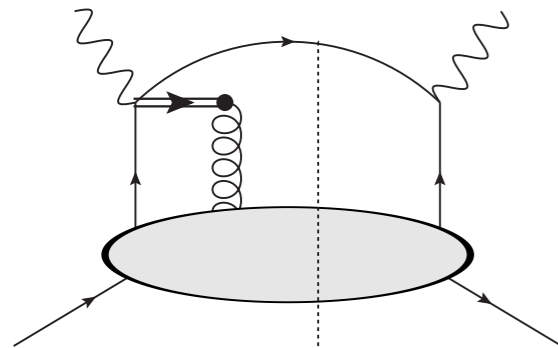

$$2MW^{\mu\nu}(q, P, S) \approx \sum_q e_q^2 \frac{1}{2} \text{Tr} [\Phi(x_B, S) \gamma^\mu \gamma^+ \gamma^\nu].$$

$$\Phi^{(a)}(x, S) \sim \langle P, S | \bar{\psi}(0) (-ig) \int_{\infty^-}^{\xi^-} d\eta^- A^+(\eta) \psi(\xi) | P, S \rangle$$

# Birth of the gauge link

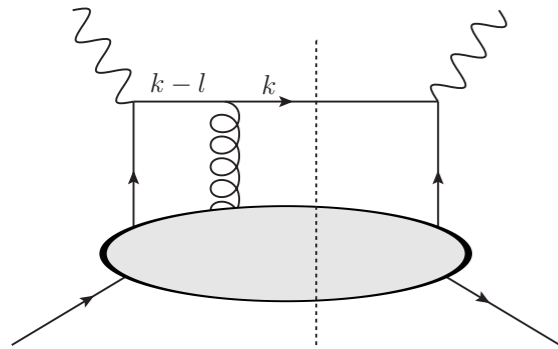

$$2MW_{\mu\nu}^{(a)} \sim \langle P, S | \bar{\psi}(0) \gamma_\mu \gamma^+ \gamma_\nu (-ig) \int_{\infty^-}^{\xi^-} d\eta^- A^+(\eta) \psi(\xi) | P, S \rangle \Big|_{\eta^+=0; \eta_T=\xi_T}$$

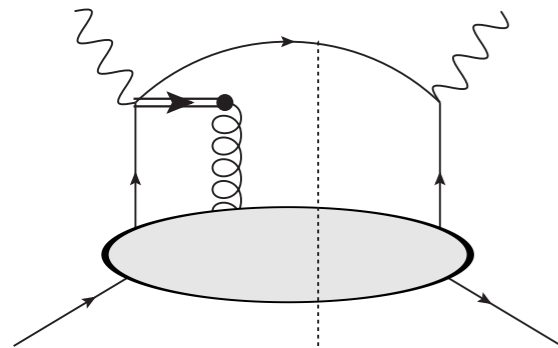

$$2MW^{\mu\nu}(q, P, S) \approx \sum_q e_q^2 \frac{1}{2} \text{Tr} [\Phi(x_B, S) \gamma^\mu \gamma^+ \gamma^\nu].$$

$$\Phi^{(a)}(x, S) \sim \langle P, S | \bar{\psi}(0) (-ig) \int_{\infty^-}^{\xi^-} d\eta^- A^+(\eta) \psi(\xi) | P, S \rangle$$

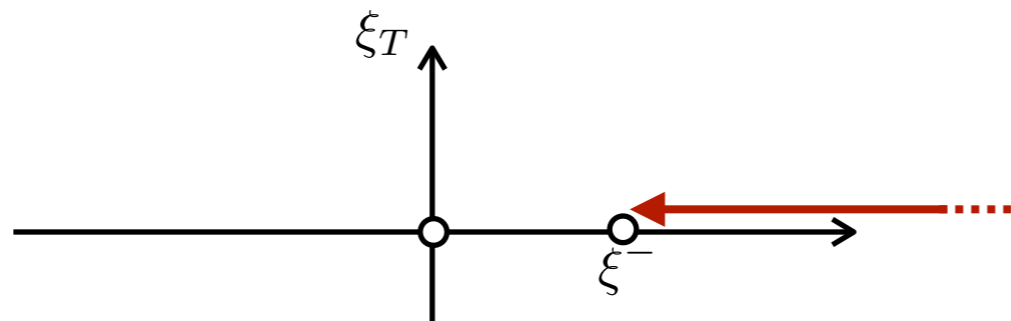

# Shape of the gauge link

---

$$\Phi(x, S) \sim \langle P, S | \bar{\psi}(0) U_{[0, \infty^-]} U_{[\infty^-, \xi^-]} \psi(\xi) | P, S \rangle$$

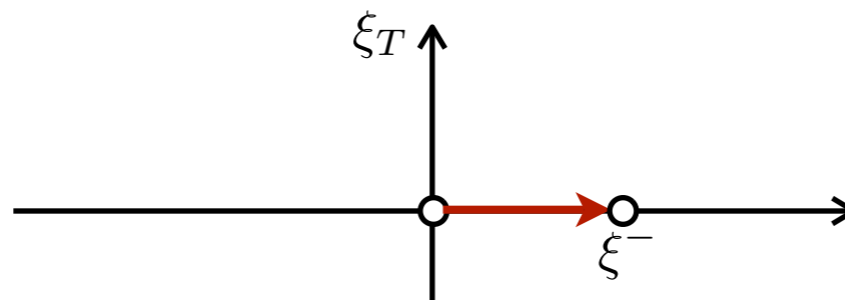
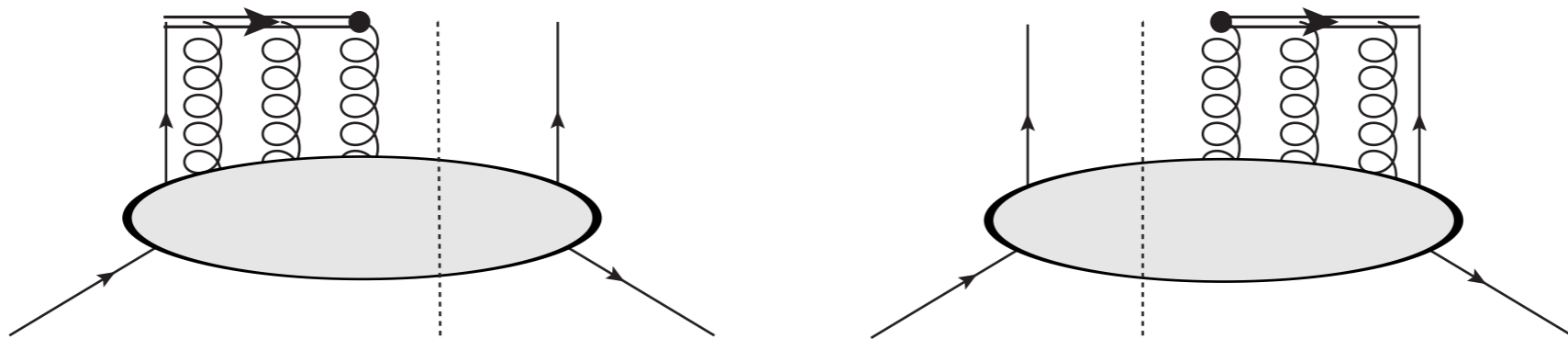





# Gauge link in Drell-Yan

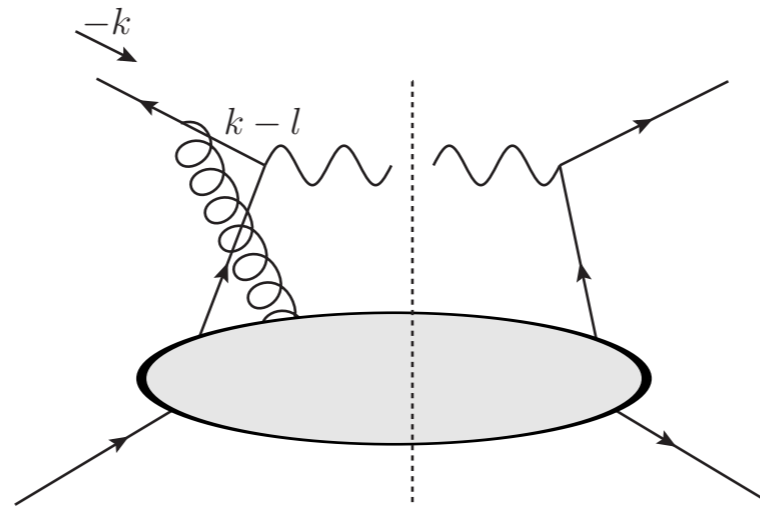

$$2MW_{\mu\nu}^{(a)} \sim \langle P, S | \bar{\psi}(0) \gamma_\mu \gamma^+ \gamma_\alpha \frac{\not{k} - \not{l} + m}{(k-l)^2 - m^2 + i\epsilon} \gamma_\nu g A^\alpha(\eta) \psi(\xi) | P, S \rangle \Big|_{\eta^+=0}$$

$$i \frac{\not{k} - \not{l} + m}{(k-l)^2 - m^2 + i\epsilon} \approx i \frac{-(-k)^- \gamma^+}{2l^+ (-k)^- + i\epsilon} \approx \frac{i}{2} \frac{\gamma^+}{-l^+ - i\epsilon}$$

$$2MW_{\mu\nu}^{(a)} \sim \langle P, S | \bar{\psi}(0) \gamma_\mu \gamma^+ \gamma_\nu (-ig) \int_{-\infty^-}^{\xi^-} d\eta^- A^+(\eta) \psi(\xi) | P, S \rangle \Big|_{\eta^+=0; \boldsymbol{\eta}_T = \boldsymbol{\xi}_T}$$

# Gauge link for TMDs

---

$$\Phi_{ij}(x, \mathbf{p}_T) = \int \frac{d\xi^- d^2\xi_T}{8\pi^3} e^{ip \cdot \xi} \langle P | \bar{\psi}_j(0) U_{[0, \xi]} \psi_i(\xi) | P \rangle \Big|_{\xi^+ = 0}$$

# Gauge link for TMDs

---

$$\Phi_{ij}(x, \mathbf{p}_T) = \int \frac{d\xi^- d^2\xi_T}{8\pi^3} e^{ip \cdot \xi} \langle P | \bar{\psi}_j(0) U_{[0, \xi]} \psi_i(\xi) | P \rangle \Big|_{\xi^+ = 0}$$

SIDIS

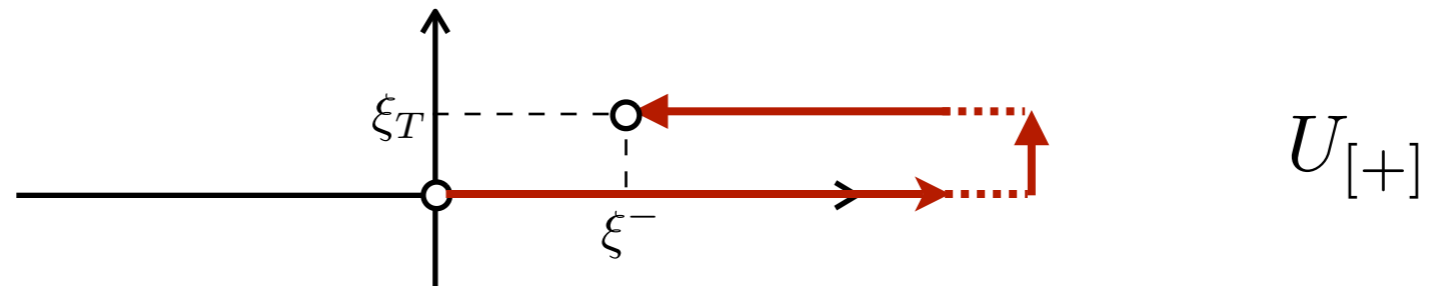

# Gauge link for TMDs

$$\Phi_{ij}(x, \mathbf{p}_T) = \int \frac{d\xi^- d^2\xi_T}{8\pi^3} e^{ip \cdot \xi} \langle P | \bar{\psi}_j(0) U_{[0, \xi]} \psi_i(\xi) | P \rangle \Big|_{\xi^+ = 0}$$

SIDIS

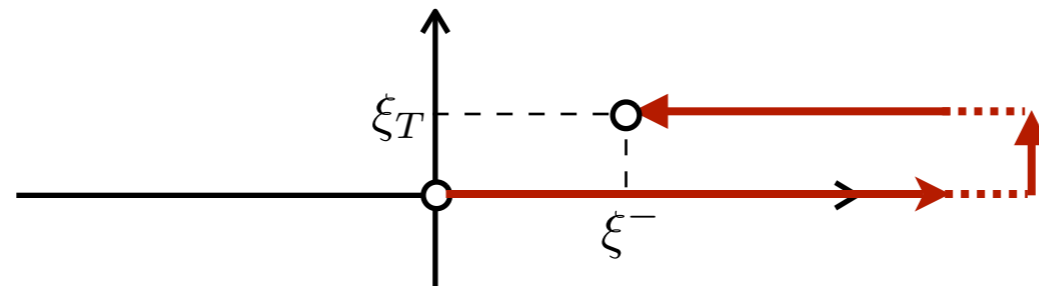

$U_{[+]}$

Drell-Yan

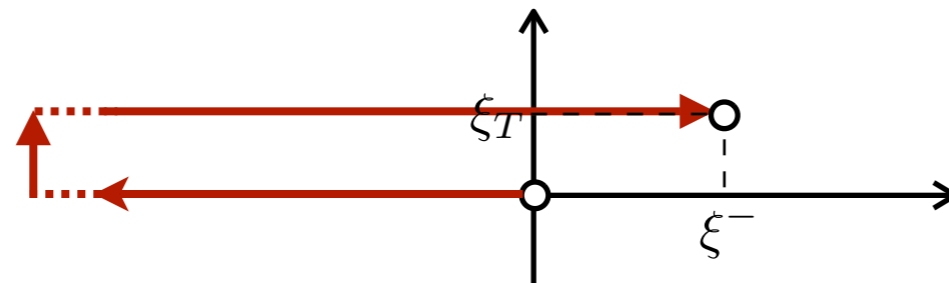

$U_{[-]}$

# Gauge link for TMDs

$$\Phi_{ij}(x, \mathbf{p}_T) = \int \frac{d\xi^- d^2\xi_T}{8\pi^3} e^{ip \cdot \xi} \langle P | \bar{\psi}_j(0) U_{[0, \xi]} \psi_i(\xi) | P \rangle \Big|_{\xi^+ = 0}$$

SIDIS

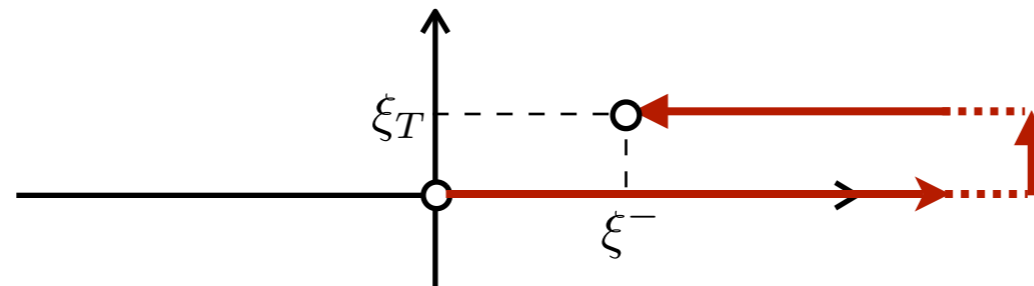

$U_{[+]}$

Drell-Yan

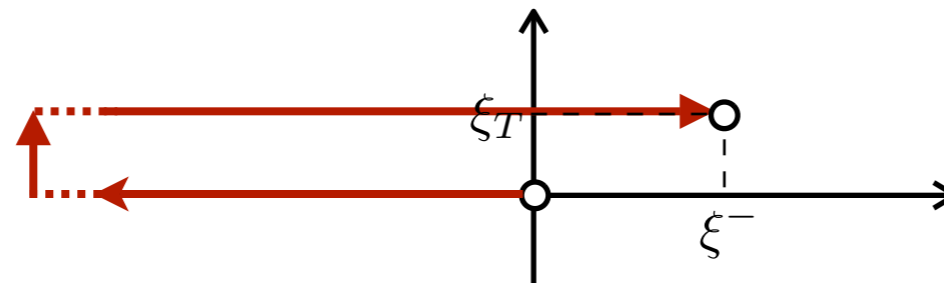

$U_{[-]}$

$pp$  to hadrons

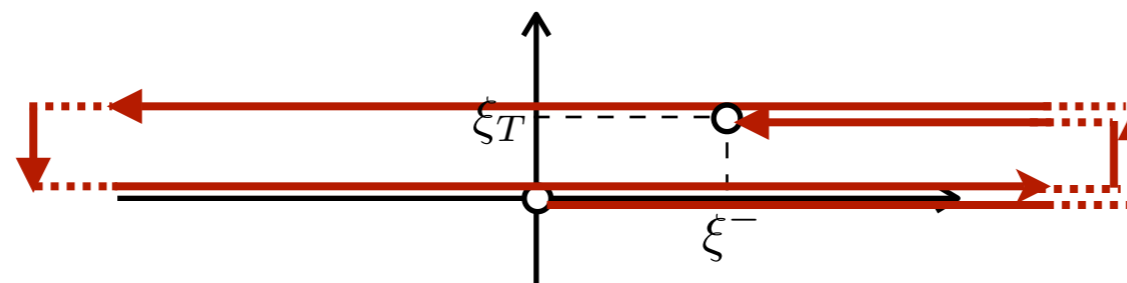

$U_{[\square]} U_{[+]}$

+ several others